

DATA SHEET EASY ROOF

Model "L-1" EVOLUTION

For 60 cells PV module 6" PORTRAIT

See modules compatibility on www.irfts.com

Note applicable to the frames whose marking is "L-1"

For :

Residential, Commercial, Public building, Agricultural and Industrial roofs

Document validated by NEW TECHNICAL INVESTIGATION n° L13CC0053

The EASY ROOF system is insured provided that the modules have approvals IEC 61215 and IEC 61730

Your nearest contact :

Non-contractual information and visuals. Subject to technical amendments without notice

Synopsis

1. Nomenclature	3
1.1. Parts provided in a kit.....	3
1.2. Optional Parts.....	3
1.3. Presentation of the parts of the kit EASY ROOF EVOLUTION	4
1.4. Presentation of the principle of assembly.....	5
2. Glossary	5
3. Under lay film	5
4. Illustration of the possible combinations assemblies	6
4.1. Possibility of module's shift in the rake direction	7
5. Parts preparation prior to installation	8
6. PV module grounding	9
7. Dimension of the photovoltaic field	10-11
7.1. Dimension of the zone of tiles to be removed	12-13
8. Technical standard of the installation and dimensioning of the EASY ROOF EVOLUTION support	14
8.1. Normal zone, common and eave installations	15
8.2. Normal zone, lateral edge or angle installations	16
8.3. Sea side zone, common and eave installations.....	17
8.4. Sea side zone, lateral edge or angle installations	18
9. Assembly instruction for EASY ROOF EVOLUTION	19
9.1. Field PV centered on rake direction	
9.1.1. Removal of the tiles.....	19
9.1.2. Definition of bottom flashing support batten	19
9.1.3. Installation of the bottom flashing support batten.....	20
Installation of the reference support batten.....	20
9.1.4. Installation of the bottom flashing.....	21
9.2. PV field positioned at the gutter/eave	
9.2.1. Removal of the tiles.....	22
9.2.2. Positioning of the flooring at the gutter/eave.....	22
9.2.3. Specific position of the reference support batten for PV field at the gutter/eave.....	23
9.2.4. Installation of the bottom metal sheet	24 à 27
9.3. Flooring installation for all PV field installation	28
9.3.1. Installation of the battens for assembly with 6 mounting brackets	29
9.3.2. Installation of the battens for assembly with 4 mounting brackets	30-31
9.3.3. Installation of leaning batten	32
9.4. Installation of the system EASY ROOF EVOLUTION	33
9.4.1. Installation of the system EASY ROOF EVOLUTION	33
9.4.2. Installation and fixing of the frames and middle brackets.....	34 à 39
9.4.3. Installation and fixing of the left flashings	40-41
9.4.4. Installation and fixing of the right flashings	42-43
9.4.5. Installation and fixing of the end brackets	44-45
9.5. Installation of the photovoltaics modules	46-47
9.5.1. Grounding	48
9.6. Put back the tiles around the PV field	49

1) Assembly guide for in roof mounting system

1.1) Easy-Roof IRFTS

Parts provided in the kit		
Number	Designation	item code
1	Frame L-1 Evolution	P001LV40... ^(*)
2	Left flashing L-1 Evolution	P002LV40... ^(*)
3	Right flashing L-1 Evolution	P003LV40... ^(*)
4	Simple fixing clamp Evolution	A001V40
5	Double fixing clamp Evolution ⁽¹⁾	A002V40
6	Double (large) fixing clamp Evolution ⁽¹⁾	A009V40
7	Double bracket Evolution	A004V40
8	Simple bracket Evolution	A003V40
9	Stainless steel rounded end screw 6x40 - A2	V003V02
10	Stainless steel hexagon screw 5x35 - A2	V001V02
11	clamp screw M6 x 40 stainless steel - A2 (module from 40 to 50) ⁽²⁾	V013V02
12	clamp screw M6 x 30 stainless steel - A2 (module from 30 to 40) ⁽²⁾	V012V02
13	EASY ROOF mounting tool L-1	OUT002V01
optional parts		
14	Double fixing black clamp Evolution ⁽¹⁾	A002V40N
15	Double (large) black fixing clamp Evolution ⁽¹⁾	A009V40N
16	Simple fixing black clamp Evolution	A001V40N
17	Simple black bracket Evolution	A003V40N
18	Lateral frieze 30/15	F001V40

* : Codification can change according to the choice of the material

1.2)

Parts not provided in the kit	
Number	Designation
a	Counter sunk head screw six lobes 5x60 stainless steel -A2(wood)
b	Counter sunk head screw six lobes 5x30 stainless steel -A2(flashings)
c	Bottom flashing / Skirt
d	Batten 120x27 ⁽³⁾
e	Batten 30x27 ⁽³⁾
f	Batten 40x15 (create a beveled) ⁽⁴⁾
g	Batten 150x18 ⁽⁴⁾
k	Batten 180x18 (skirt) ⁽⁴⁾
m	Bottom metal sheet ⁽⁵⁾

- (1) Use large clamp for PV modules width lower than 990 mm.
- (2) Choose the length of screw to be used according to the PV module thickness .
- (3) Dimensions of these support batten can vary according to the design of the roof structure and the geographical zone of the building site, see table p. 14 to 17. These support batten will have to be same thickness as the tiles batten .
- (4) Dimensions of this bottom flashing batten can vary according to the roof slope , see table p. 11.
- (5) For installation at the gutter.

1.3)

Parts representation

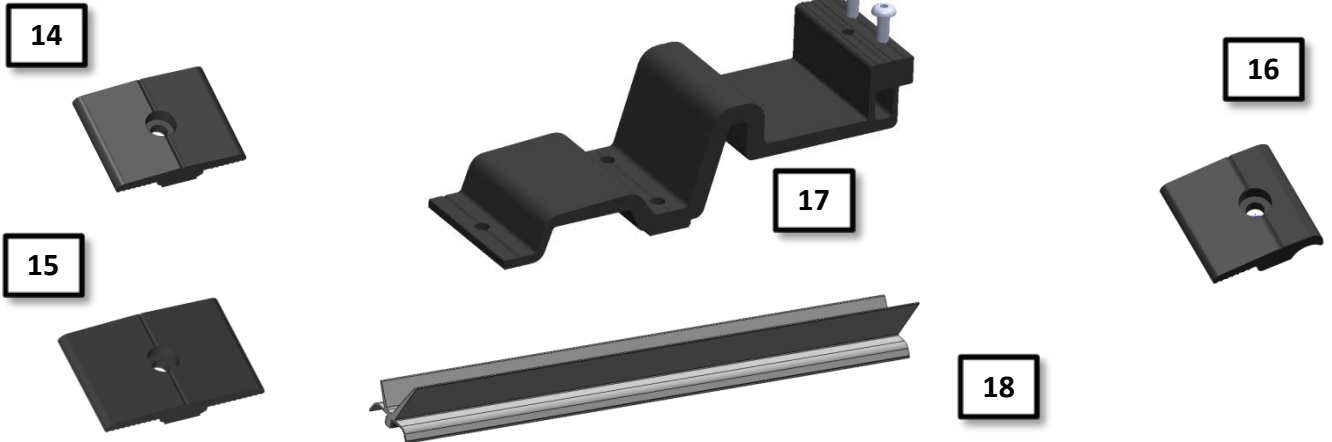
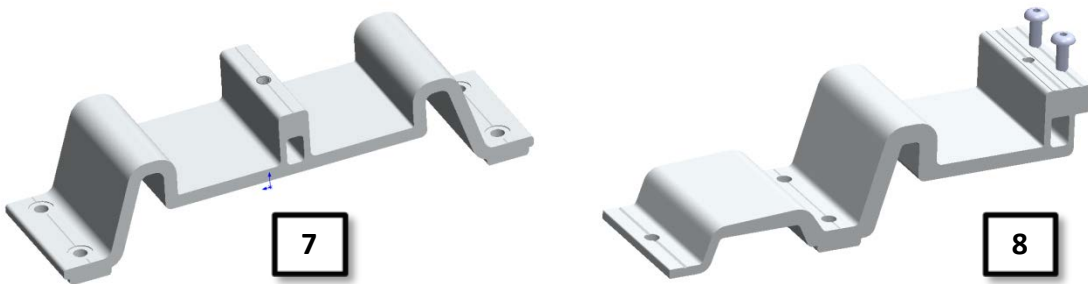
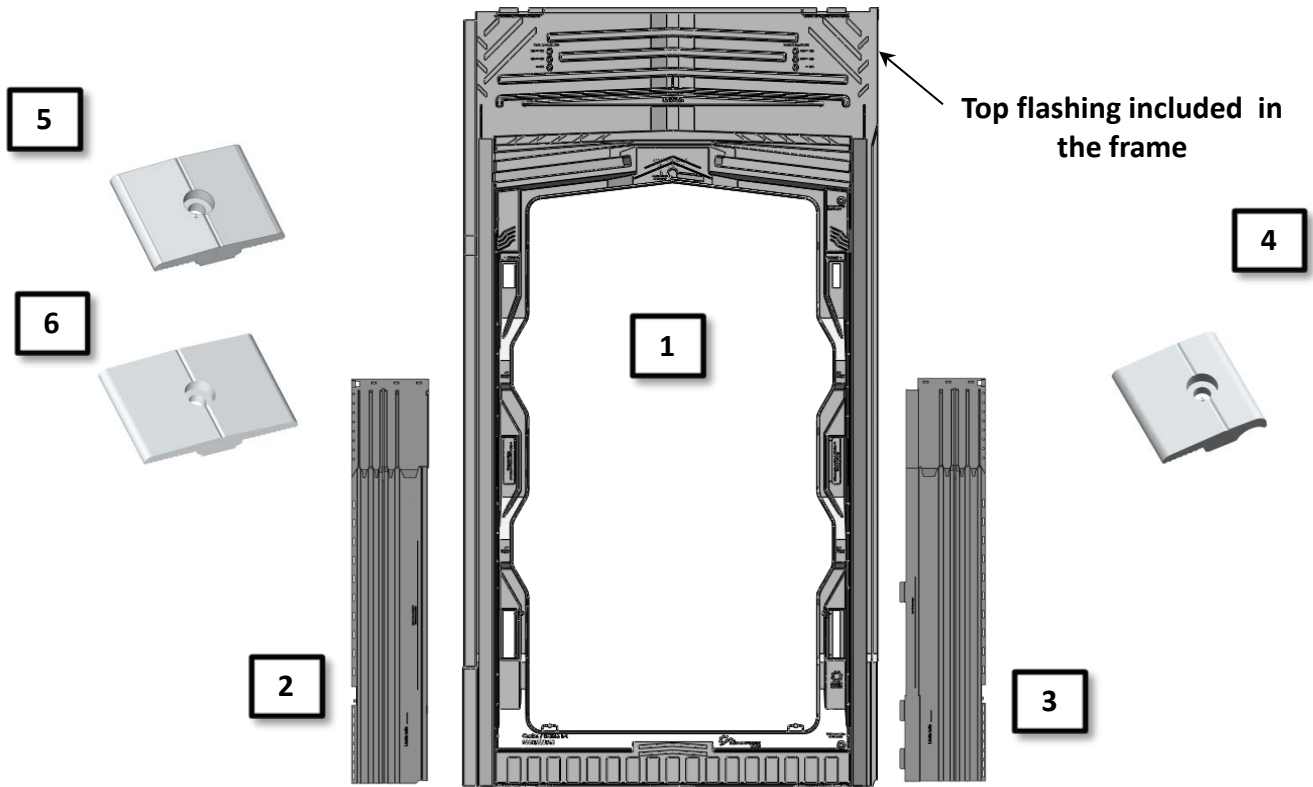

Model "L-1" 60 Cells 6" Portrait

1.4) 2 lateral flashings by frame height

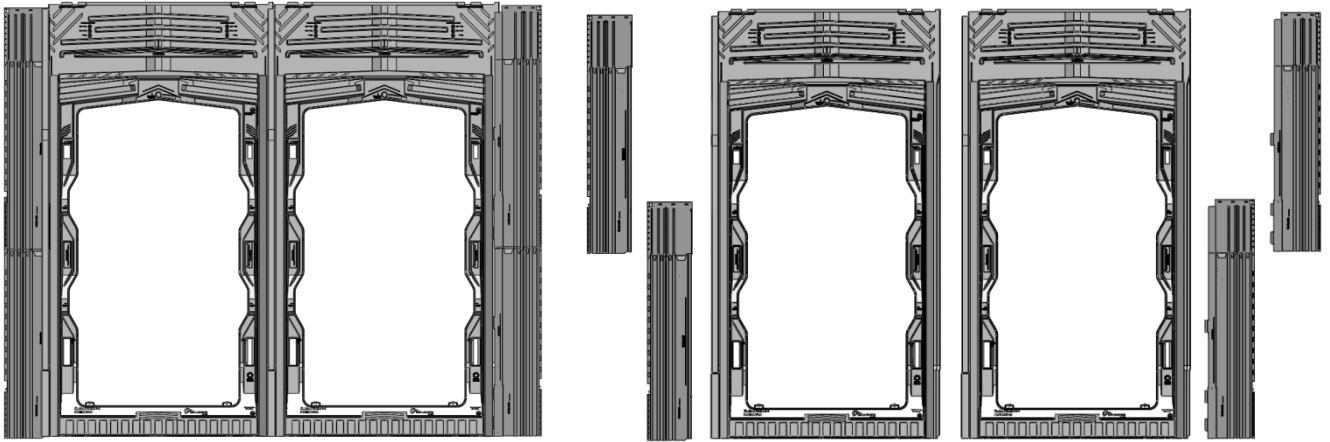

(Exploded View)

2) Parts marking

Parts marking	definition
P001LV40... ^(*)	frame
P002LV40... ^(*)	Right flashing
P003LV40... ^(*)	Left flashing

* : Codification can change according to the choice of the material



3) Roofing felt / Roofing underlay

We impose the installation of a roofing felt / roofing underlay before the installation of the system of integration EASY-ROOF. This roofing felt/roofing underlay must comply with regulation

4) Use of different flashings according to the configuration of the photovoltaic field

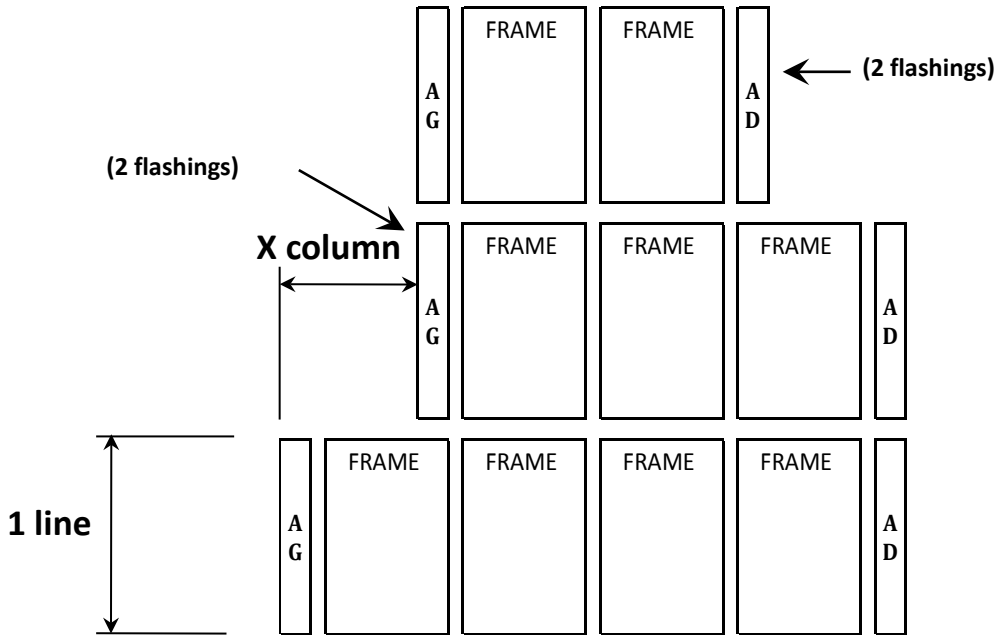

Multiple combination for the clearing of roof window or chimney

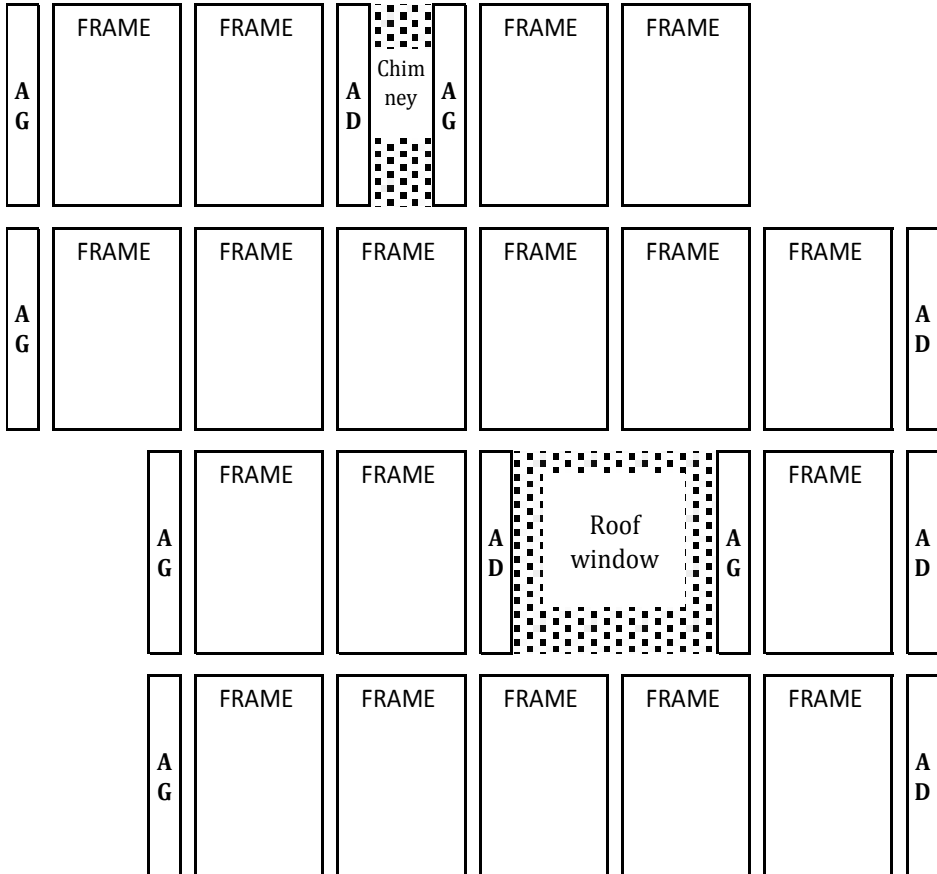

Information and visual noncontractual. Subject to engineering changes without notice.

Model "L-1" 60 Cells 6" Portrait

4.1) Possible shift of the panels in the vertical direction

Shift with constant step

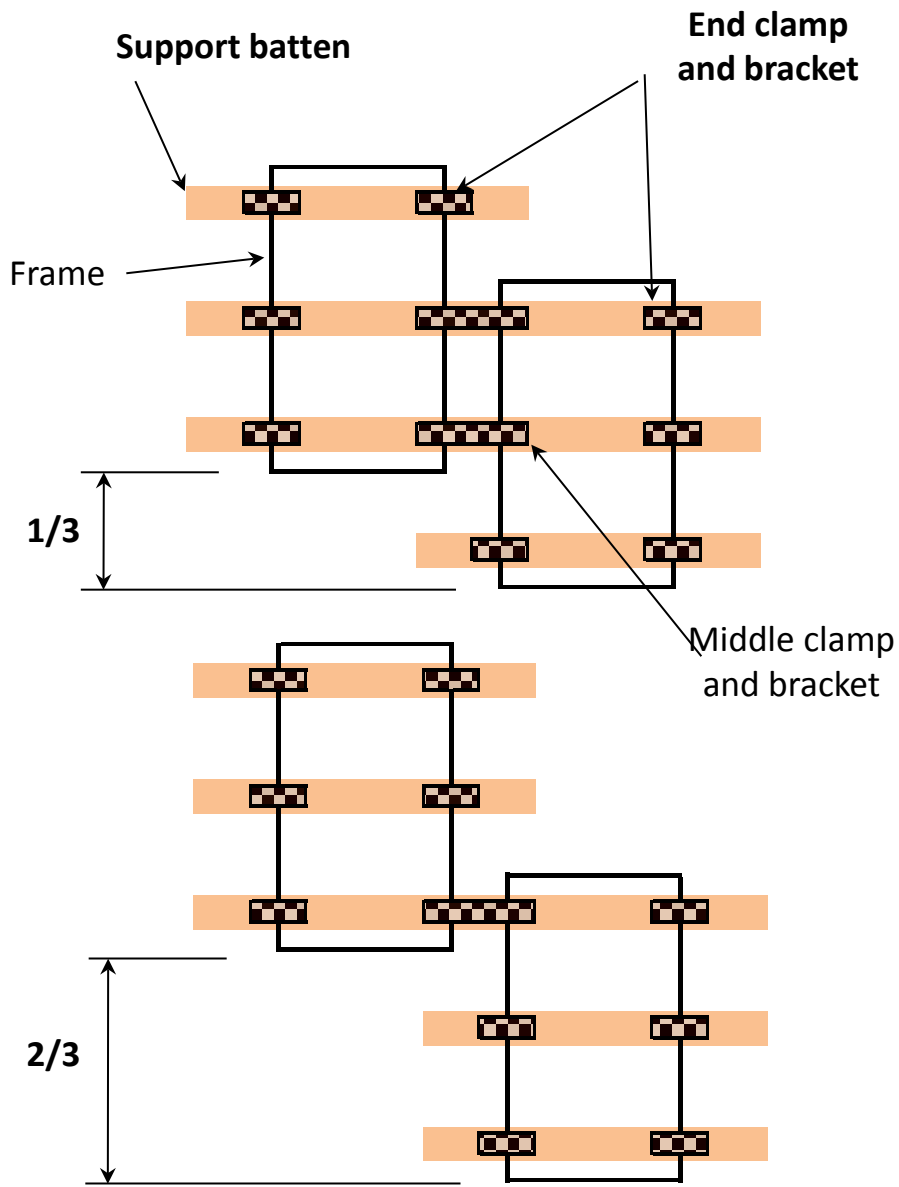

Variable shift

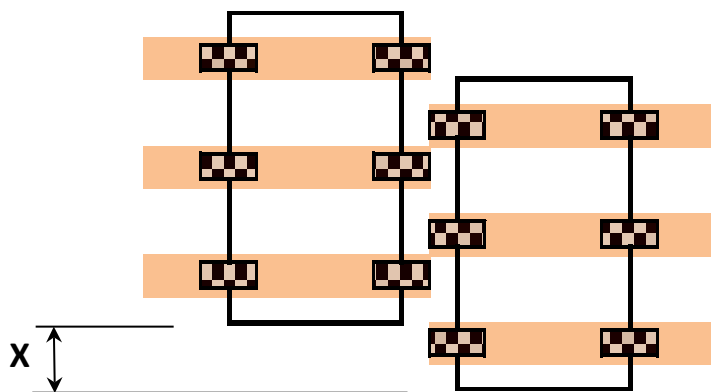

Model "L-1" 60 Cells 6" Portrait

5) Parts to be prepared before assembly of the kit

1°) Preparation of the frames

1°) Remove the 6 module centering wedge

2°) Remove the frieze support

3°) For an installation with 6 fixings per module, cut out and remove the two plugs

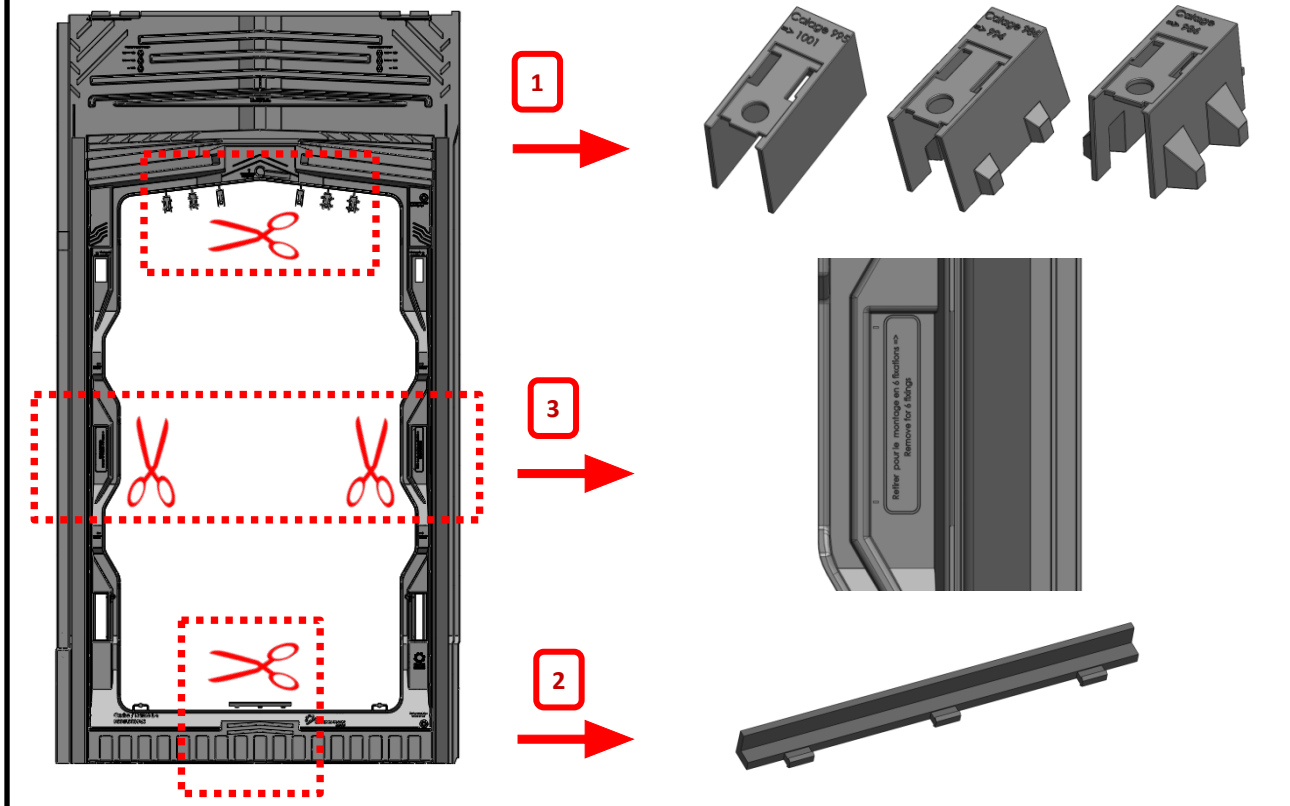

2°) Middle clamp preparation.

Pre mount the module wedge in the slides of each middle clamp (5).

Select the model of module centering wedge according to the module width.

For a module width < or equal to 990 mm, Use imperatively large clamp.

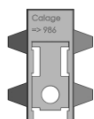

Module Width ≤ 985



$986 \leq$ Module Width ≤ 994



$995 \leq$ Module Width ≤ 1001

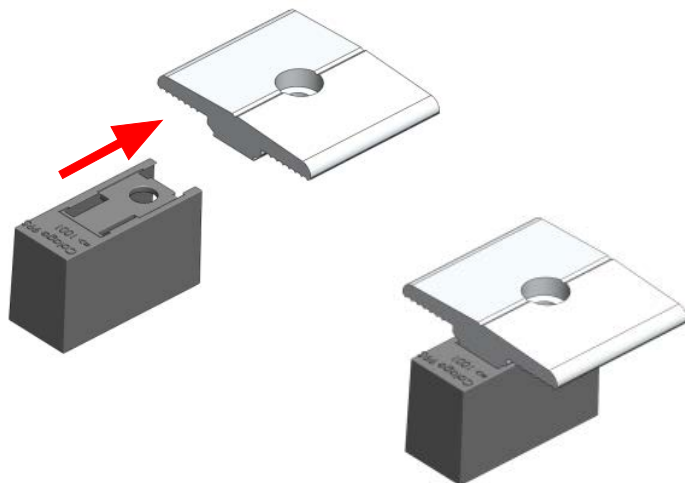

Model "L-1" 60 Cells 6" Portrait

6) PV module Grounding

To ground the PV module, several solutions are possible:

a) Connect the ground wire directly to the PV module.



b) Connect the ground wire to one middle bracket (5) for two PV modules.

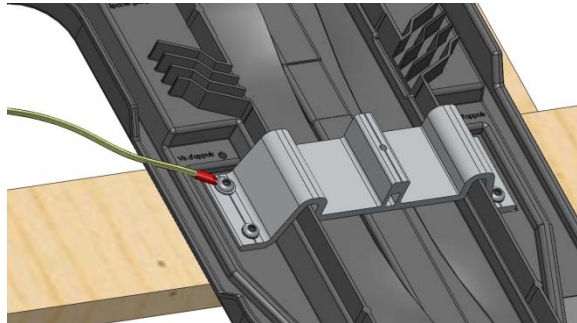

b1) The link between the PV module and the middle bracket (5) connected to the ground can be made via the middle clamp. (see page 48 of this document)

B2) The link between the PV module and the middle bracket (5) connected to the ground can be made via a claw. (see manufacturer documentation)

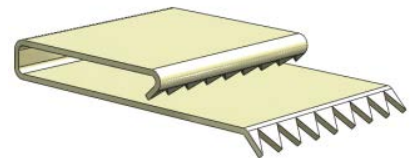

Claw on PV module

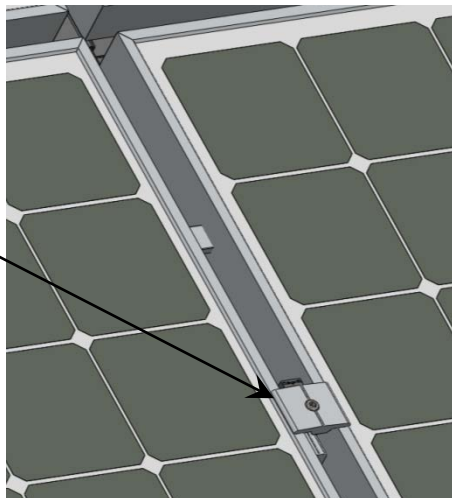

Middle clamp

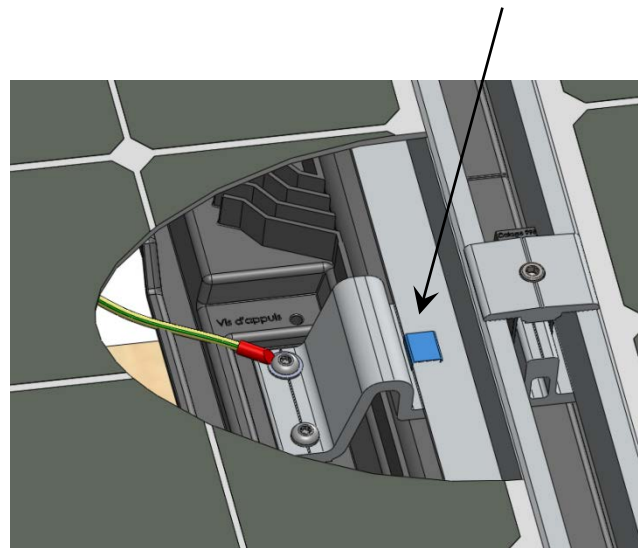

(View with local cut)

7) Dimension of the PV field (Visible Part of the installation)

1°) Width calculation of the visible field

Dimension of the photovoltaic field	
Field width (mm)	
PV field centered on rake direction	$X = 1020 \times N_{bx} + (2 \times 40)$
Lateral eave installation	$X = 1020 \times N_{bx} + (2 \times 25)$

N_{bx} : Number of column of PV module

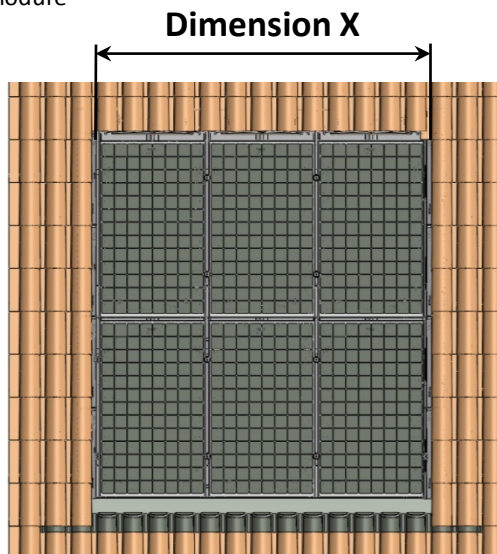

a) Common installation (with tiles on both side)

Ex : $(1020 \times 12) + (2 \times 40) = 12320$

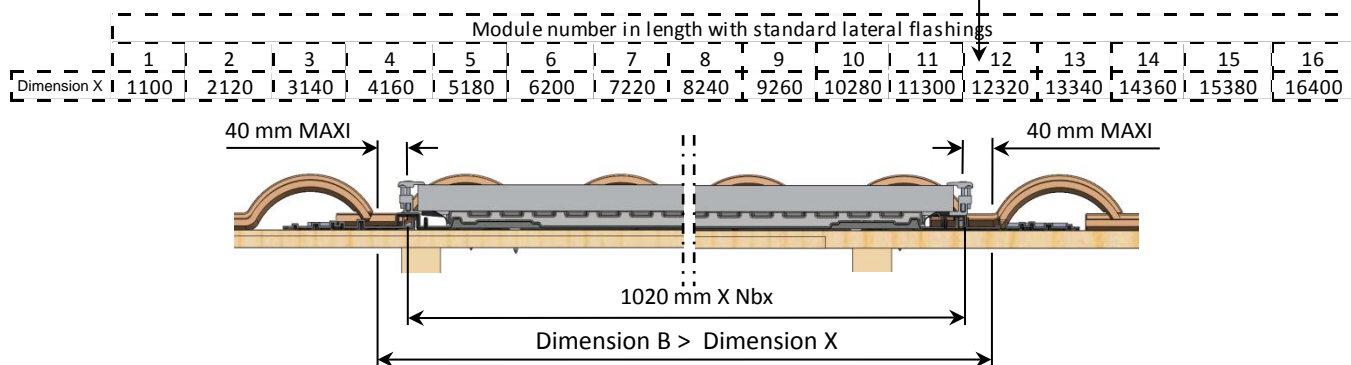

Positioning the photovoltaic field

Dimension B must be positioned with the tiles hollow.

b) Edge installation (no tiles on each side)

Ex : $(1020 \times 12) + (2 \times 25) = 12290$

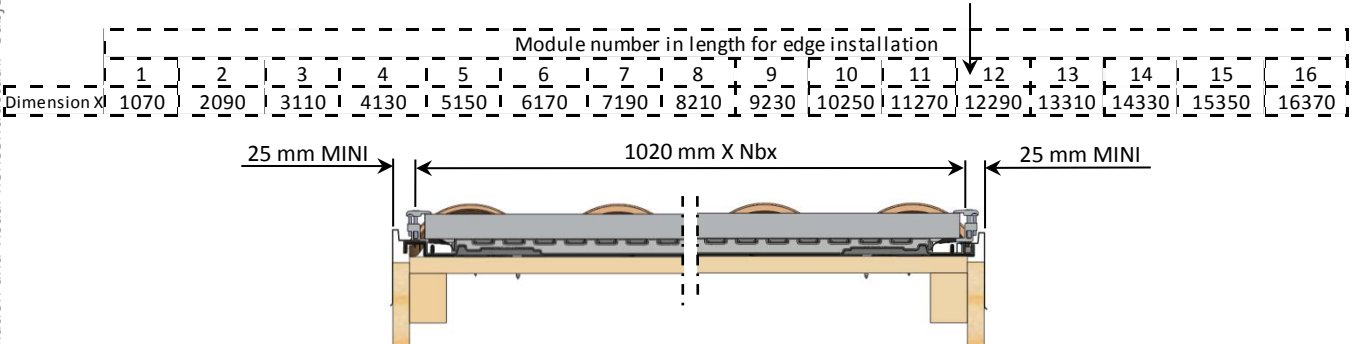

Model "L-1" 60 Cells 6" Portrait

7) Dimension of the PV field (Visible Part of the installation)

2°) Height calculation of the visible field

Dimension of the photovoltaic field	
Field height (mm)	
PV field centered on rake direct	$Y = \text{Step} \times (\text{Nby}-1) + 1614 + 114$
Gutter / eave installation	

Step : Step of the system in rake direction, see table below

Nby : Number of line of PV module

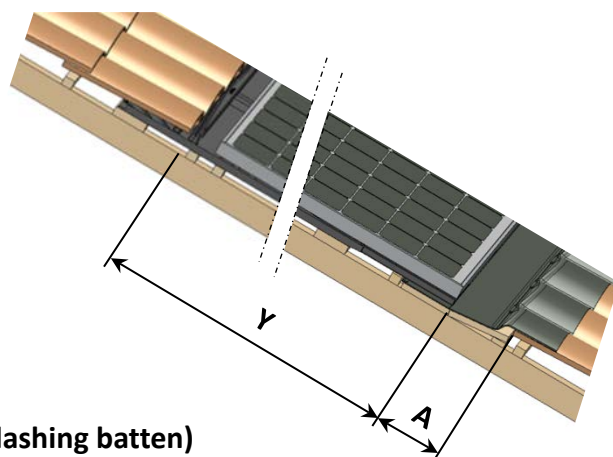
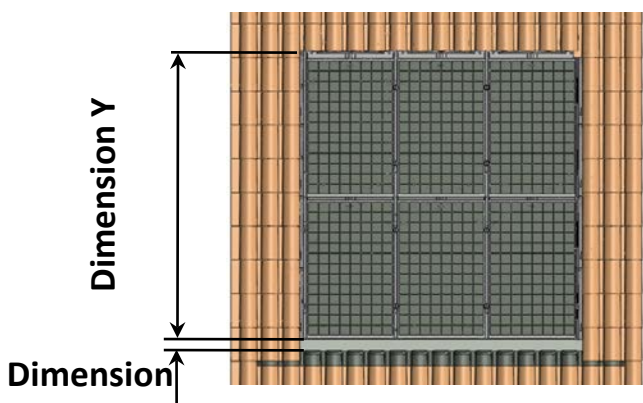

A a) Determination of dimension A (Bottom flashing batten)
The « C » dimension is the Minimum batten width necessary to avoid reverse slope on the bottom flashing. It's possible to use a wider batten, this will simply raise up the PV field.

Roof slope (°)	Minimum batten width C dimension (mm)	Mini A dimension (mm)
from 10 to 12	250	260
from 13 to 16	220	230
from 17 to 19	180	190
from 20 to 24	150	160
from 25 to 50	120	130

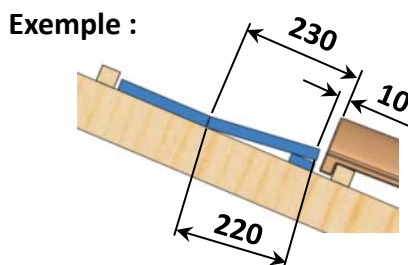
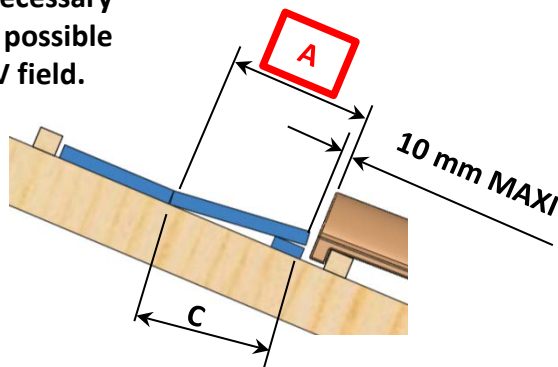

b) Determination of dimension Y

Warning : Please check the PV module compatibility list on : www.irfts.com

		Length PV module (lg)		
		≤ 1645	$1646 \leq lg \leq 1665$	$1666 \leq lg \leq 1685$
System vertical step		1655	1675	1695
		Dimension Y		
modules number in height	1	1728	1728	1728
	2	3383	3403	3423
	3	5038	5078	5118
	4	6693	6753	6813
	5	8348	8428	8508
	6	10003	10103	10203
	7	11658	11778	11898

Ex: $(1655 \times (3-1)) + 1614 + 114 = 5038$

**Dimension of the visible field =
Dimension Y + Dimension A**

7.1) Dimension of the Easy-Roof system (With flashings)

1°) Width calculation of the system to be installed

Dimension of the photovoltaic field	
Field width (mm)	
PV field centered on rake direction	$L = 1020 \times N_{bx} + (2 \times 189)$
Lateral eave installation	$L = 1020 \times N_{bx} + (2 \times 25)$

Nbx : Number of column of PV module

The length of the support batten d^* is equal to the dimension L + a sufficient length on each side to lean on the rafter exterior to the frame.

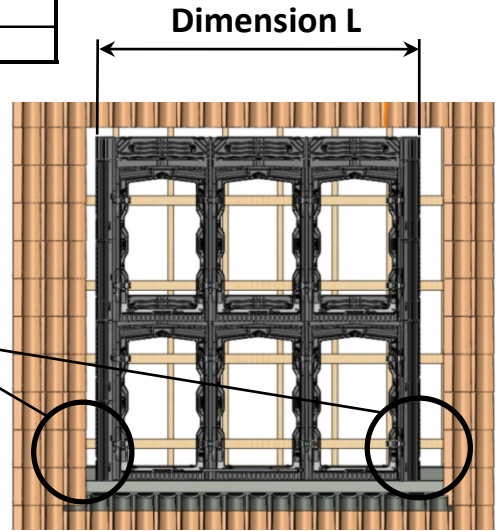

a) Common installation (with tiles on both side)

Ex: $(1020 \times 12) + (2 \times 189) = 12618$

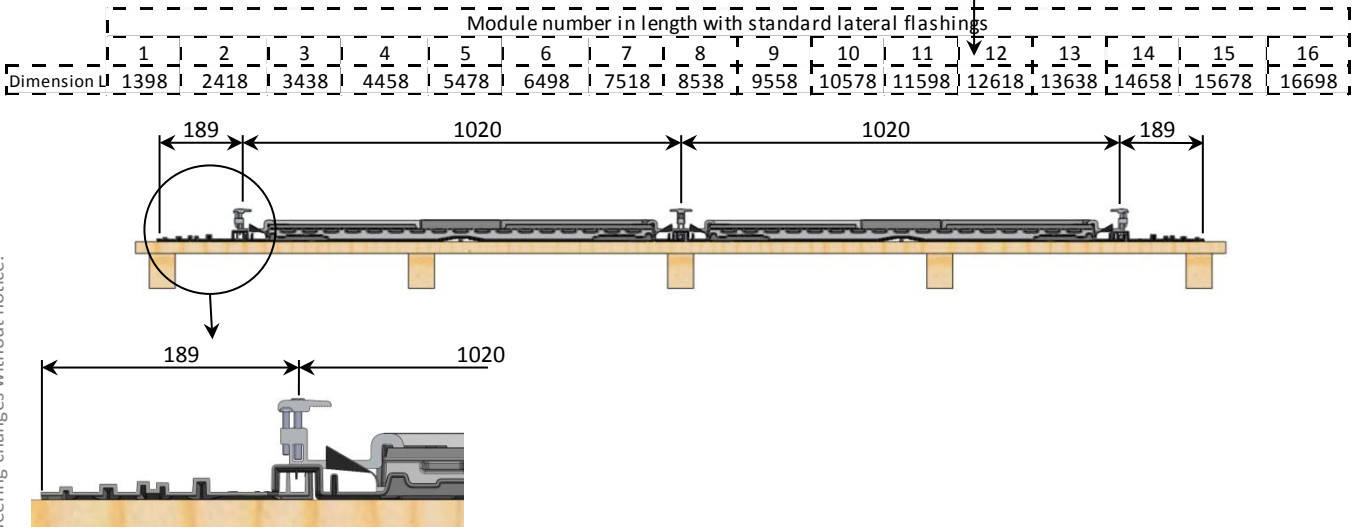

b) Edge installation (no tiles on each side)

Ex: $(1020 \times 12) + (2 \times 25) = 12290$

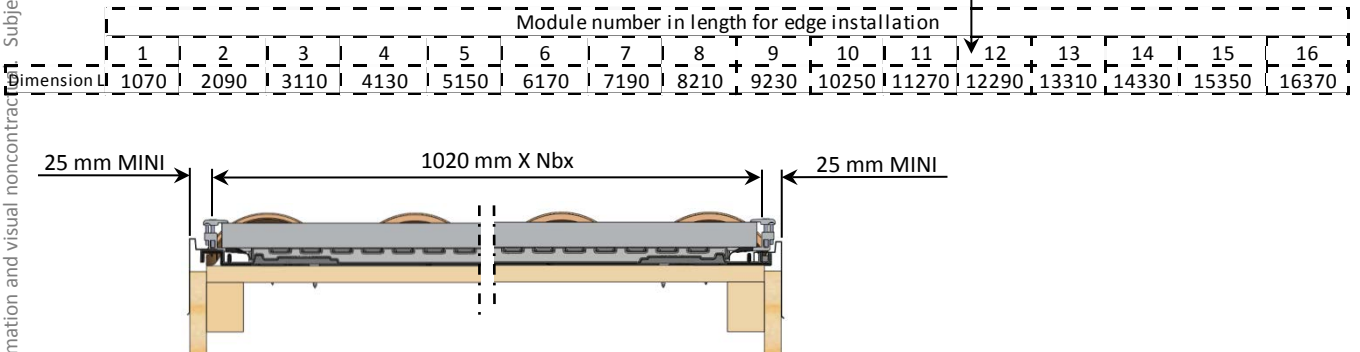

Subject to engineering changes without notice. Information and visual noncontractual.

* Reference nomenclature

Model "L-1" 60 Cells 6" Portrait

7.1) Dimension of the Easy-Roof system (With flashings)

2°) Height calculation of the system to be installed

Dimension of the photovoltaic field	
Field height (mm)	
PV field centered on rake direct	$H = \text{Step} \times (\text{Nby}-1) + 1614 + 342$
Gutter/ eave installation	$H = \text{Step} \times (\text{Nby}-1) + 1614 + 342$

Step : Step of the system in rake direction, see table below

Nby : number of line of PV module

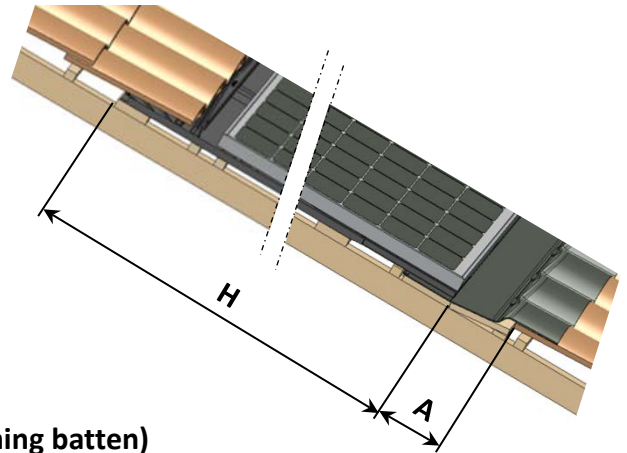
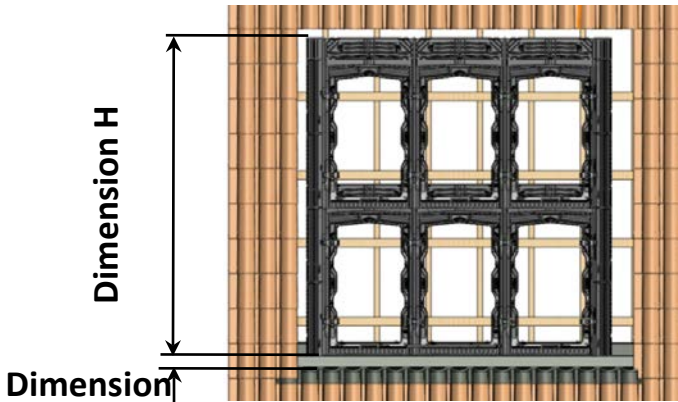

A) Determination of dimension A (Bottom flashing batten)

The « C » dimension is the Minimum batten width necessary to avoid reverse slope on the bottom flashing. It's possible to use a wider batten, this will simply raise up the PV field.

Roof slope (°)	Minimum batten width C dimension (mm)	Mini A dimension (mm)
from 10 to 12	250	260
from 13 to 16	220	230
from 17 to 19	180	190
from 20 to 24	150	160
from 25 to 50	120	130

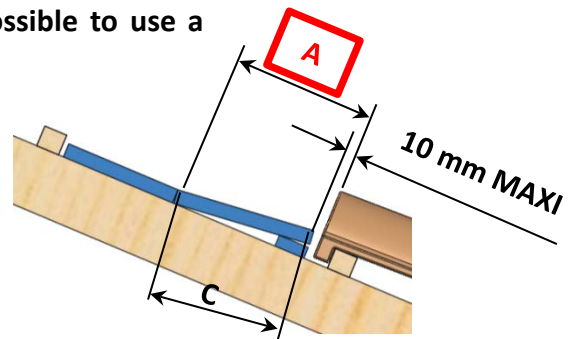

b) Determination of dimension H

Warning : Please check the PV module compatibility list on : www.irfts.com

System vertical step	Lenth PV module (lg)			
	≤ 1645	$1646 \leq lg \leq 1665$	$1666 \leq lg \leq 1685$	
1655	1675	1695		
Dimension H				
modules number in height	1	1956	1956	1956
	2	3611	3631	3651
	3	5266	5306	5346
	4	6921	6981	7041
	5	8576	8656	8736
	6	10231	10331	10431
	7	11886	12006	12126

Exemple :

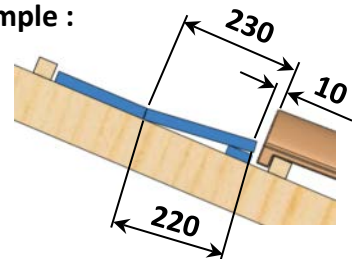

Dimension of the Easy Roof system with flashing = Dimension H + Dimension A

Ex : $(1655 \times (3-1)) + 1614+342 = 5266$

8)

Technical standard

The selection and the dimensioning of the support batten of the EASY-ROOF system are done according to the type of roof structure.

The Easy Roof system can be installed on roofs with a slope from 10° to 50° only.

Use the tables of the following pages to determine the dimension of the support battens .

The number of fixing points per panel can be 4 or 6 according to the support batten choosen.

The values on the following tables apply only for the geographical zones from 1 to 4 of the regulation snow and wind according to standard NF EN 1991-1 - 4 and for an altitude lower than 900m. For zone 5 a technical study and of feasibility will have to be made on a case-by-case basis.

It is imperative to respect these instructions of dimensioning.

Note that the conditions of guarantee can be applied only if the implementation has been done in accordance with the rules prescribed in the present note and with different the appendices to which it could refer.

8.1) Normal zone, common and eave installations

From 10° to 50°, normal zone (category IIIa) 2 slopes roof

Normal

From 10° to 50°, normal zone (category IIIa) 2 slopes roof													Length counter sunk head screw stainless steel A2 (Screw for batten to rafters)			
Zone 1				Zone 2				Zone 3				Zone 4				
Number of bracket	Thickness batten	Mini width support batten	Number of screw by batten	Number of bracket	Thickness batten	Mini width support batten	Number of screw by batten	Number of bracket	Thickness batten	Mini width support batten	Number of screw by batten	Number of bracket		Thickness batten	Mini width support batten	Number of screw by batten

Common Installation	Centre distance ≤ 600		Truss or rafters centre distance		4	15	250	2	4	15	300	2	4	15	300	2	4	15	300	2	4	15	300	2	5x60/32							
						22	150	2		22	150	2		22	150	2		22	150	2		22	150	2		22	150	2	22	150	2	5x60/32
						27	120	2		27	120	2		27	120	2		27	120	2		27	120	2		27	120	2	27	120	2	5x60/33
						40	100	2		40	100	2		40	100	2		40	100	2		40	100	2		40	100	2	40	100	2	5x70/32
					22	150	3	22	150	3	22	150	3	22	150	3	22	150	3	22	150	3	22	150	3	5x60/32						
					27	120	3	27	120	3	27	120	3	27	120	3	27	120	3	27	120	3	27	120	3	5x60/32						
				40	100	3	40	100	3	40	100	3	40	100	3	40	100	3	40	100	3	40	100	3	5x70/32							
				4	40	130	3	4	40	130	3	4	40	130	3	4	40	130	3	4	40	130	3	4	40	130	3	5x70/32				
				6	40	100	3	6	40	100	3	6	40	100	3	6	40	100	3	6	40	100	3	6	40	100	3	5x70/32				
				4	22	200	4	4	22	200	4	4	22	200	4	4	22	200	4	4	22	200	4	4	22	200	4	5x60/32				
				27	180	4	27	180	4	27	180	4	27	180	4	27	180	4	27	180	4	27	180	4	27	180	4	5x60/32				
				40	100	4	40	100	4	40	100	4	40	100	4	40	100	4	40	100	4	40	100	4	40	100	4	5x70/32				
				4	40	130	4/3(1)	4	40	130	4/3(1)	4	40	130	4/3(1)	4	40	130	4/3(1)	4	40	130	4/3(1)	4	40	130	4/3(1)	5x70/32				
				6	40	100	4/3(1)	6	40	100	4/3(1)	6	40	100	4/3(1)	6	40	100	4/3(1)	6	40	100	4/3(1)	6	40	100	4/3(1)	5x70/32				

Gutter /eave	Centre distance ≤ 600		Truss or rafters centre distance		4	15	250	2	4	15	250	2	4	15	250	2	4	15	250	2	4	15	250	2	5x60/32							
						22	150	2		22	150	2		22	150	2		22	150	2		22	150	2		22	150	2	22	150	2	5x60/32
						27	120	2		27	120	2		27	120	2		27	120	2		27	120	2		27	120	2	27	120	2	5x60/33
						40	100	2		40	100	2		40	100	2		40	100	2		40	100	2		40	100	2	40	100	2	5x70/32
					22	150	3	22	150	3	22	150	3	22	150	3	22	150	3	22	150	3	22	150	3	5x60/32						
					27	120	3	27	120	3	27	120	3	27	120	3	27	120	3	27	120	3	27	120	3	5x60/32						
				40	100	3	40	100	3	40	100	3	40	100	3	40	100	3	40	100	3	40	100	3	40	100	3	5x70/32				
				4	40	130	3	4	40	130	3	4	40	130	3	4	40	130	3	4	40	130	3	4	40	130	3	5x70/32				
				6	40	100	3	6	40	100	3	6	40	100	3	6	40	100	3	6	40	100	3	6	40	100	3	5x70/32				
				4	22	200	4	4	22	200	4	4	22	200	4	4	22	200	4	4	22	200	4	4	22	200	4	5x60/32				
				27	180	4	27	180	4	27	180	4	27	180	4	27	180	4	27	180	4	27	180	4	27	180	4	5x60/32				
				40	100	4	40	100	4	40	100	4	40	100	4	40	100	4	40	100	4	40	100	4	40	100	4	5x70/32				
				4	40	130	4/3(1)	4	40	130	4/3(1)	4	40	130	4/3(1)	4	40	130	4/3(1)	4	40	130	4/3(1)	4	40	130	4/3(1)	5x70/32				
				6	40	100	4/3(1)	6	40	100	4/3(1)	6	40	100	4/3(1)	6	40	100	4/3(1)	6	40	100	4/3(1)	6	40	100	4/3(1)	5x70/32				

(1) : 4 for wood frame / 3 for metal frame.

(2) : wood installation on rake direction.

8.2) Normal zone, side edge or angle installations

Normal

From 10° to 50°, normal zone (category IIIa) 2 slopes roof																Length mm for counter sunk head screw stainless steel A2 (Screw for batten to rafters)
Zone 1				Zone 2				Zone 3				Zone 4				
Number of batten	Thickness batten	Mini width support batten	Number of screw by batten	Number of batten	Thickness batten	Mini width support batten	Number of screw by batten	Number of batten	Thickness batten	Mini width support batten	Number of screw by batten	Number of batten	Thickness batten	Mini width support batten	Number of screw by batten	

Side edge	Centre distance ≤ 600		Truss or rafters centre distance		600 < centre distance ≤ 900		Truss or rafters centre distance		Centre distance ≤ 1500		metal truss		centre distance ≤ 1500 (2)		wood structure on rake direction		Centre distance ≤ 1500 (2)		Wood or metal frame		Length mm for counter sunk head screw stainless steel A2 (Screw for batten to rafters)				
	4		2		3		3		4		3		4		4		4/3(1)		4/3(1)						
	15	250	2	4	15	250	2	4	15	250	2	4	15	250	2	4	15	250	2	4		15	250	2	4
	22	150	2	4	22	150	2	4	22	150	2	4	22	150	2	4	22	150	2	4		22	150	2	4
	27	120	2	4	27	120	2	4	27	120	2	4	27	120	2	4	27	120	2	4		27	120	2	4
	40	100	2	4	40	100	2	4	40	100	2	4	40	100	2	4	40	100	2	4		40	100	2	4
22	150	3	4	22	150	3	4	22	150	3	4	22	150	3	4	22	150	3	4	22	150	3	4		
27	120	3	4	27	120	3	4	27	120	3	4	27	120	3	4	27	120	3	4	27	120	3	4		
40	100	3	4	40	100	3	4	40	100	3	4	40	100	3	4	40	100	3	4	40	100	3	4		
4	40	130	3	4	40	130	3	4	40	130	3	4	40	130	3	4	40	130	3	4	40	130	3	4	
6	40	100	3	6	40	100	3	6	40	100	3	6	40	100	3	6	40	100	3	6	40	100	3	6	
4	22	200	4	4	22	200	4	4	22	200	4	4	22	200	4	4	22	200	4	4	22	200	4	4	
27	180	4	4	27	180	4	4	27	180	4	4	27	180	4	4	27	180	4	4	27	180	4	4		
40	100	4	4	40	100	4	4	40	100	4	4	40	100	4	4	40	100	4	4	40	100	4	4		
4	40	130	4/3(1)	4	40	130	4/3(1)	4	40	130	4/3(1)	4	40	130	4/3(1)	4	40	130	4/3(1)	4	40	130	4/3(1)	4	
6	40	100	4/3(1)	6	40	100	4/3(1)	6	40	100	4/3(1)	6	40	100	4/3(1)	6	40	100	4/3(1)	6	40	100	4/3(1)	6	

Angle	Centre distance ≤ 600		truss or rafters centre distance		600 < Centre distance ≤ 900		truss or rafters centre distance		Centre distance ≤ 1500		Metal truss		Centre distance (2)		wood structure on rake direction		Centre distance ≤ 1500 (2)		wood or metal structure		Length mm for counter sunk head screw stainless steel A2 (Screw for batten to rafters)				
	4		2		3		3		4		3		4		4		4/3(1)		4/3(1)						
	15	250	2	4	15	250	2	4	15	250	2	4	15	250	2	4	15	250	2	4		15	250	2	4
	22	150	2	4	22	150	2	4	22	150	2	4	22	150	2	4	22	150	2	4		22	150	2	4
	27	120	2	4	27	120	2	4	27	120	2	4	27	120	2	4	27	120	2	4		27	120	2	4
	40	100	2	4	40	100	2	4	40	100	2	4	40	100	2	4	40	100	2	4		40	100	2	4
22	150	3	4	22	150	3	4	22	150	3	4	22	150	3	4	22	150	3	4	22	150	3	4		
27	120	3	4	27	120	3	4	27	120	3	4	27	120	3	4	27	120	3	4	27	120	3	4		
40	100	3	4	40	100	3	4	40	100	3	4	40	100	3	4	40	100	3	4	40	100	3	4		
4	40	130	3	4	40	130	3	4	40	130	3	4	40	130	3	4	40	130	3	4	40	130	3	4	
6	40	100	3	6	40	100	3	6	40	100	3	6	40	100	3	6	40	100	3	6	40	100	3	6	
4	22	200	4	4	22	200	4	4	22	200	4	4	22	200	4	4	22	200	4	4	22	200	4	4	
27	180	4	4	27	180	4	4	27	180	4	4	27	180	4	4	27	180	4	4	27	180	4	4		
40	100	4	4	40	100	4	4	40	100	4	4	40	100	4	4	40	100	4	4	40	100	4	4		
4	40	130	4/3(1)	4	40	130	4/3(1)	4	40	130	4/3(1)	4	40	130	4/3(1)	4	40	130	4/3(1)	4	40	130	4/3(1)	4	
6	40	100	4/3(1)	6	40	100	4/3(1)	6	40	100	4/3(1)	6	40	100	4/3(1)	6	40	100	4/3(1)	6	40	100	4/3(1)	6	

(1) : 4 for wood frame / 3 for metal frame.

(2) : wood installation on rake direction.

8.3) Sea side zone, common and eave installations

seaside

From 10° to 50° - exposed site (category I) 2 slopes roof															
Zone 1				Zone 2				Zone 3				Zone 4			
Number of batten	Thickness batten	Mini width support batten	Number of screw by batten	Number of batten	Thickness batten	Mini width support batten	Number of screw by batten	Number of batten	Thickness batten	Mini width support batten	Number of screw by batten	Number of batten	Thickness batten	Mini width support batten	Number of screw by batten

Length mm for counter sunk head screw stainless steel A2 (Screw for batten to rafters)

Common Installation	Centre distance ≤ 600		600 < centre distance ≤ 900		Centre distance ≤ 1500		centre distance ≤ 1500 (2)		Centre distance ≤ 1500 (2)		5x60/32 5x60/32 5x60/33 5x70/32 5x60/32 5x60/32 5x60/32 5x70/32 5x70/32 5x70/32 5x70/32
	Truss or rafters	centre distance	Truss or rafters	centre distance	metal truss	wood structure on rake direction	wood structure on rake direction	Wood or metal frame	Wood or metal frame		
	6	15 250 2	6	15 300 2	4	40 130 3	6	22 200 4	4	40 130 4/3(1)	
	6	22 150 2	6	22 150 3	6	40 100 3	6	27 180 4	6	40 100 4/3(1)	
	6	27 120 2	6	27 120 3	6	40 100 3	6	40 100 4	6	40 100 4/3(1)	
	6	40 100 2	6	40 100 3	6	40 100 3	6	40 100 4	6	40 100 4/3(1)	

Gutter / Eave	Centre distance ≤ 600		600 < centre distance ≤ 900		Centre distance ≤ 1500		centre distance ≤ 1500 (2)		Centre distance ≤ 1500 (2)		5x60/32 5x60/32 5x60/33 5x70/32 5x60/32 5x60/32 5x60/32 5x70/32 5x70/32 5x70/32
	Truss or rafters	centre distance	Truss or rafters	centre distance	metal truss	wood structure on rake direction	wood structure on rake direction	Wood or metal frame	Wood or metal frame		
	6	15 250 2	6	15 250 2	4	40 130 3	6	22 200 4	4	40 130 4/3(1)	
	6	22 150 2	6	22 150 3	6	40 100 3	6	27 180 4	6	40 100 4/3(1)	
	6	27 120 2	6	27 120 3	6	40 100 3	6	40 100 4	6	40 100 4/3(1)	
	6	40 100 2	6	40 100 3	6	40 100 3	6	40 100 4	6	40 100 4/3(1)	

(1) : 4 for wood frame / 3 for metal frame.
 (2) : wood installation on rake direction.

8.4) Sea side zone, side edge or angle installations

seaside

From 10° to 50° - exposed site (category I) 2 slopes roof														Length mini for counter sunk head screw stainless steel A2 (Screw for batten to rafters)		
Zone 1				Zone 2				Zone 3				Zone 4				
Number of batten	Thickness batten	Mini width support batten	Number of screw by batten	Number of batten	Thickness batten	Mini width support batten	Number of screw by batten	Number of batten	Thickness batten	Mini width support batten	Number of screw by batten	Number of batten	Thickness batten		Mini width support batten	Number of screw by batten

Side edge	Centre distance ≤ 600		Truss or rafters centre distance		6	15	250	2	6	15	250	2	6	15	250	2	6	15	250	2	5x60/32
	22	150	2	22		150	2	22		150	2	22		150	2	22		150	2	5x60/32	
	27	120	2	27		120	2	27		120	2	27		120	2	27		120	2	5x60/33	
	40	100	2	40		100	2	40		100	2	40		100	2	40		100	2	5x70/32	
	600 < centre distance ≤ 900		Truss or rafters centre distance		6	22	150	3	6	22	150	3	6	22	150	3	6	22	150	3	5x60/32
	27	120	3	27		120	3	27		120	3	27		120	3	27		120	3	5x60/32	
40	100	3	40	100		3	40	100		3	40	100		3	40	100		3	5x70/32		
Centre distance ≤ 1500		metal truss		4	40	130	3	4	40	130	3	4	40	130	3	4	40	130	3	5x70/32	
6	40	100	3		6	40	100		3	6	40		100	3	6		40	100	3		5x70/32
centre distance ≤ 1500 (2)		wood structure on rake direction		6	22	200	4	4	22	200	4	4	22	200	4	6	22	200	4	5x60/32	
27	180	4	27		180	4	27		180	4	27		180	4	27		180	4	5x60/32		
40	100	4	40		100	4	40		100	4	40		100	4	40		100	4	5x70/32		
Centre distance ≤ 1500 (2)		Wood or metal frame		4	40	130	4/3(1)	4	40	130	4/3(1)	4	40	130	4/3(1)	4	40	130	4/3(1)	5x70/32	
6	40	100	4/3(1)		6	40	100		4/3(1)	6	40		100	4/3(1)	6		40	100	4/3(1)		5x70/32

Angle	Centre distance ≤ 600		Truss or rafters centre distance		6	15	250	2	6	15	250	2	6	15	250	2	6	15	250	2	5x60/32
	22	150	2	22		150	2	22		150	2	22		150	2	22		150	2	5x60/32	
	27	120	2	27		120	2	27		120	2	27		120	2	27		120	2	5x60/33	
	40	100	2	40		100	2	40		100	2	40		100	2	40		100	2	5x70/32	
	600 < centre distance ≤ 900		Truss or rafters centre distance		6	22	150	3	6	22	150	3	6	22	150	3	6	22	150	3	5x60/32
	27	120	3	27		120	3	27		120	3	27		120	3	27		120	3	5x60/32	
40	100	3	40	100		3	40	100		3	40	100		3	40	100		3	5x70/32		
Centre distance ≤ 1500		metal truss		4	40	130	3	4	40	130	3	4	40	130	3	4	40	130	3	5x70/32	
6	40	100	3		6	40	100		3	6	40		100	3	6		40	100	3		5x70/32
centre distance ≤ 1500 (2)		wood structure on rake direction		6	22	200	4	4	22	200	4	4	22	200	4	6	22	200	4	5x60/32	
27	180	4	27		180	4	27		180	4	27		180	4	27		180	4	5x60/32		
40	100	4	40		100	4	40		100	4	40		100	4	40		100	4	5x70/32		
Centre distance ≤ 1500 (2)		Wood or metal frame		4	40	130	4/3(1)	4	40	130	4/3(1)	4	40	130	4/3(1)	4	40	130	4/3(1)	5x70/32	
6	40	100	4/3(1)		6	40	100		4/3(1)	6	40		100	4/3(1)	6		40	100	4/3(1)		5x70/32

(1) : 4 for wood frame / 3 for metal frame.

(2) : wood installation on rake direction.

9) Instruction for the assembly of the Easy-Roof system

9.1.1) PV field centered on rake direction

This section of the installation manual relates only to installation of PV field centered in the rake direction. For the installations on the eave go directly on page 22 of this document

Remove the tiles of the photovoltaic field, for L and H to see page 12 and 13

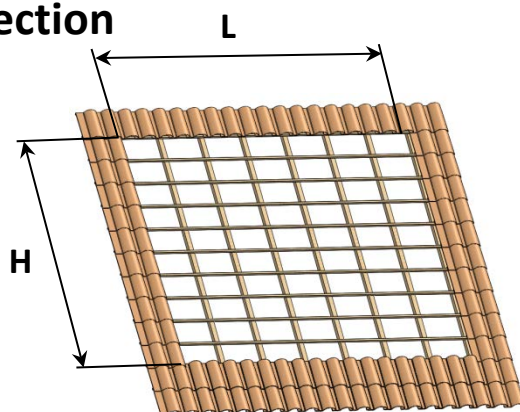

9.1.2) Definition of bottom flashing support batten

1° Define the thickness of the bottom flashing batten according to the thickness of the support batten (d)*.

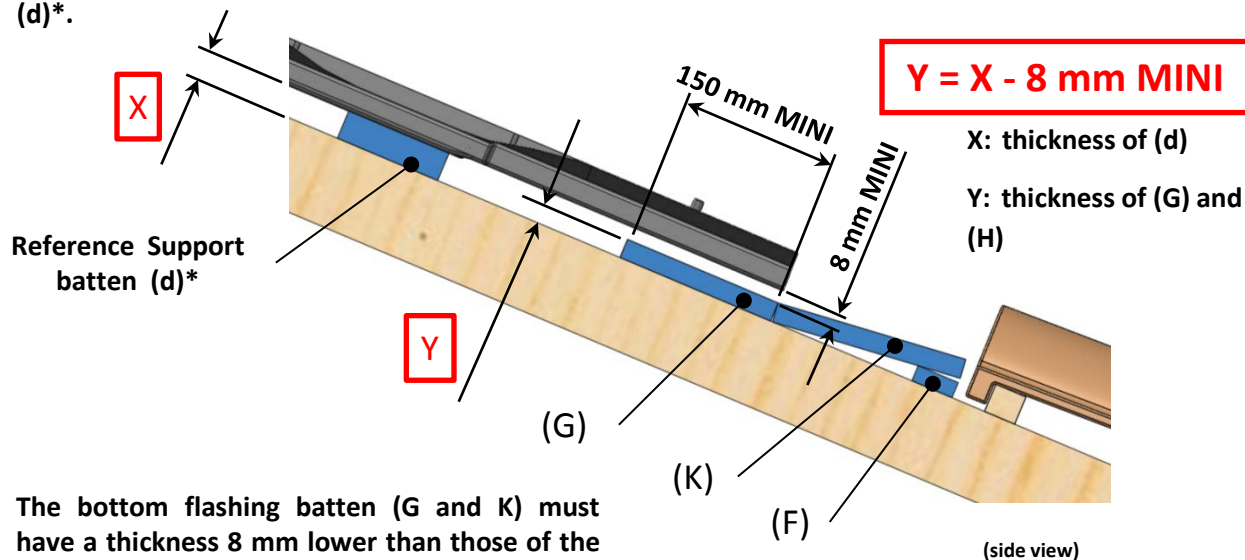

The bottom flashing batten (G and K) must have a thickness 8 mm lower than those of the support batten (d).

2° Position the batten (F) in order to have the top of the bottom flashing batten (H) flush with the water flow of the tile, eventually slightly higher (a few millimeters).

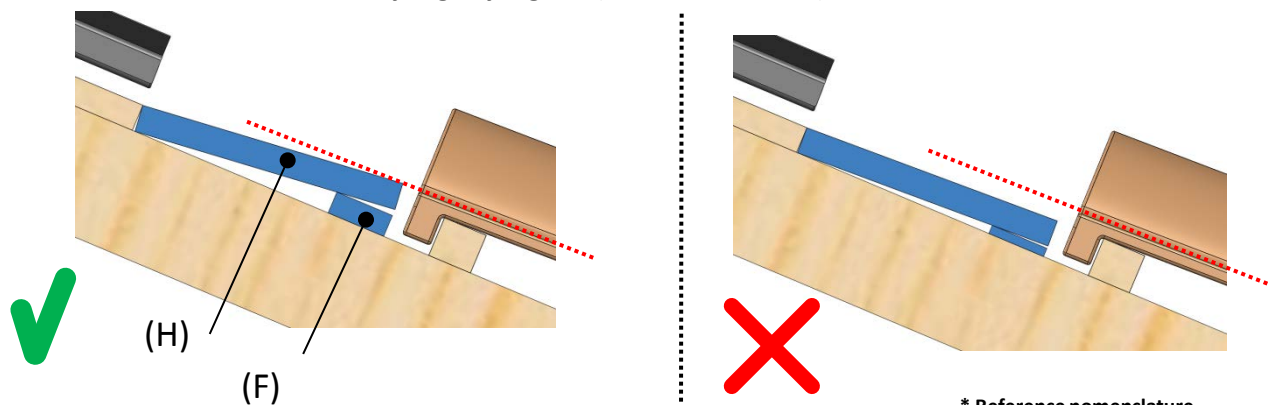

9.1.3) Installation of the bottom flashing support batten and the reference support batten.

1°) Determination of dimension A (Bottom flashing batten)

The « C » dimension is the Minimum batten width necessary to avoid reverse slope on the bottom flashing. It's possible to use a wider batten, this will simply raise up the PV field.

Roof slope (°)	Minimum batten width C dimension (mm)	Mini A dimension (mm)
from 10 to 12	250	260
from 13 to 16	220	230
from 17 to 19	180	190
from 20 to 24	150	160
from 25 to 50	120	130

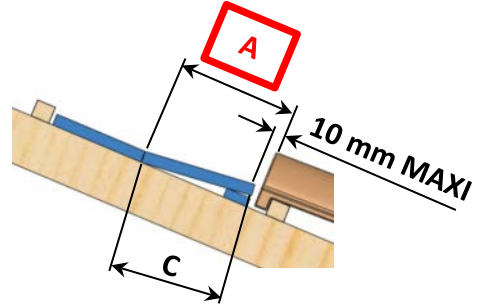

2°) Set up the bottom flashing batten at 10 mm MAXIMUM to the top of the tile . Use the wood (G) and (K) defined in the preceding operation. Screw with stainless screws 5x60 milled head.

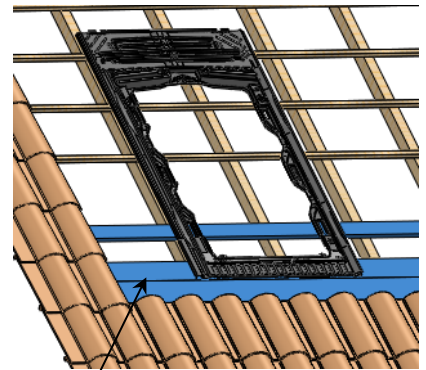
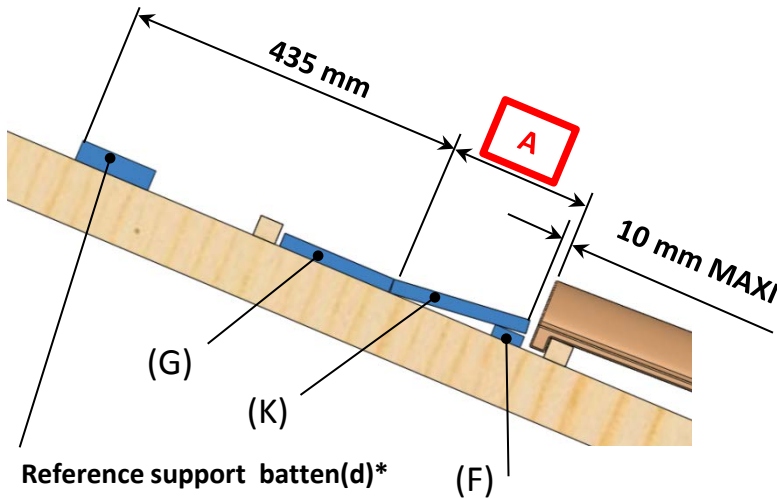

The bottom flashing batten and the bottom flashing itself will have to be 2 tiles longer on each side of the PV field.

3°) Set up the first reference support batten d*. Position this support batten 435 mm to the break of the bottom flashing flooring. (equal to 435mm + A from the top of the tile)
Screw the support batten following the recommendations page 15 to 18 to know the type and the number of screws to be used.

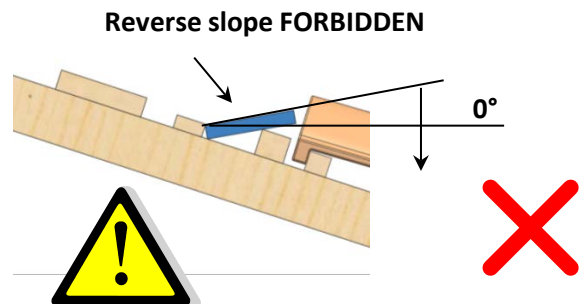
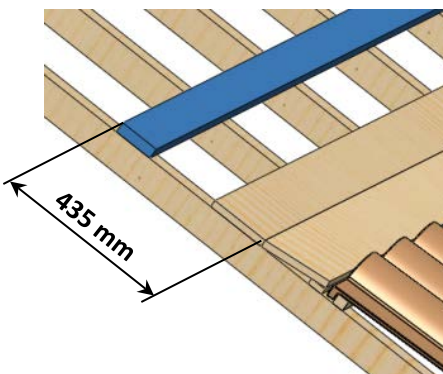

* Reference nomenclature

9.1.4) Installation of the bottom flashing

Set up the bottom flashing. Attention not to stick the ends and the higher edge, in order to be able to flip over the ends.

The overlap on the tiles will be made according to the tiles model.

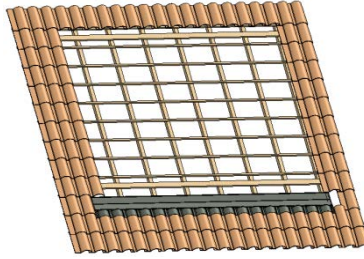

Make sure that the tiles are covered with 150 mm MINI.

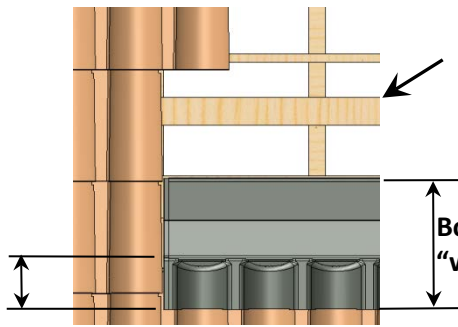

reference support batten (d)

Bottom flashing "width"

150 mm MINI

$$\text{Bottom flashing MINI "width"} = (2 \times 150) + \text{dimension A}$$

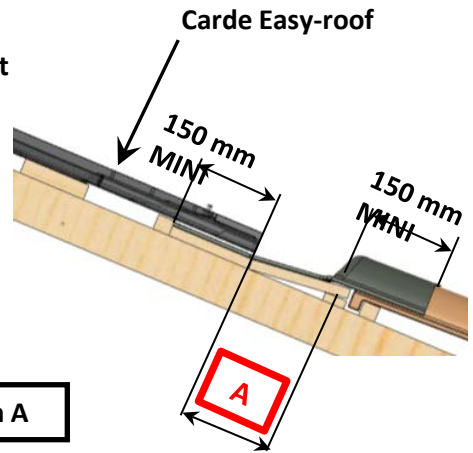

Carde Easy-roof

150 mm MINI

150 mm MINI

A

Make a flip over from 10 to 15 mm on the higher edge of the bottom flashing over all the width of the PV field

(Left side of PV field)

(Right side of PV field)

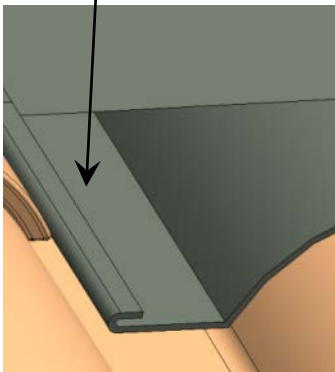
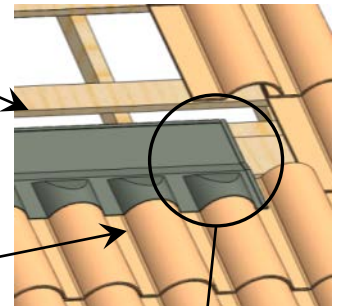
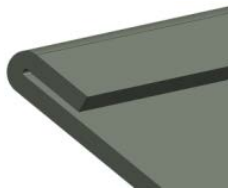
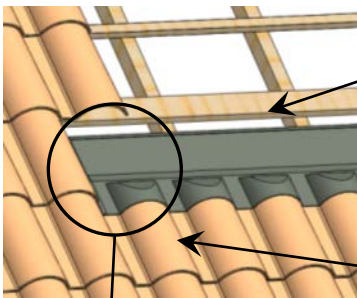

Make a flip over from 10 to 15 mm on the right and left side of the bottom flashing on all the height

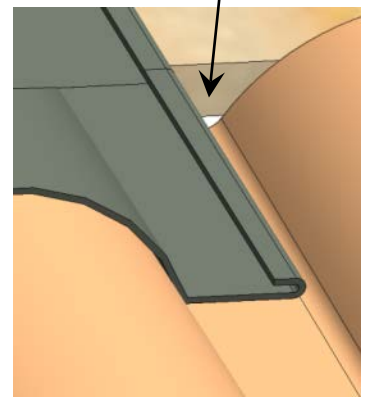

* Reference nomenclature

9.2.1) PV field positioned at the gutter/eave

This section of the assembly guide relates only to the installations of PV field positioned at the gutter/eave

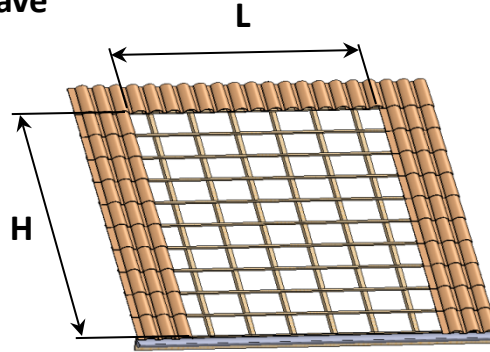

Remove the tiles of the photovoltaic field, for L and H to see page 12 and 13

9.2.2) Positioning of the flooring at the gutter/eave

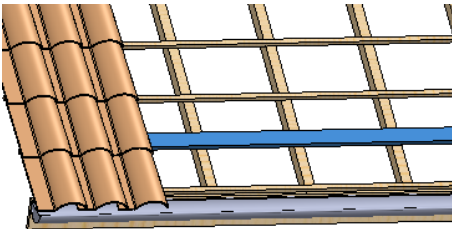

Set up the first support batten at 435 mm from the first batten or the eave batten (tilting lath).

Screw the support batten following the recommendations page 15 to 18 to know the type and the number of screws to be used.

Reference support batten (d)*

* Reference nomenclature



CAUTION: The low part of PV field (with the gutter) must imperatively be on the same plan as the flooring of the system. In the contrary case the dimension of 435 mm is not applicable any more. It is necessary to go move up the PV field in the rake direction. The dimension of positioning must be redefined, see page 23.

Reverse slope FORBIDDEN

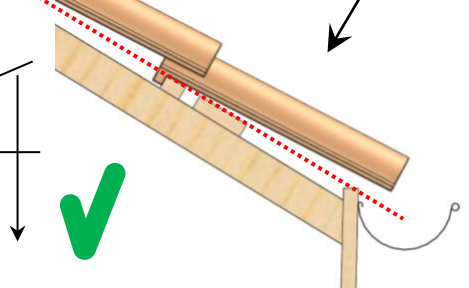
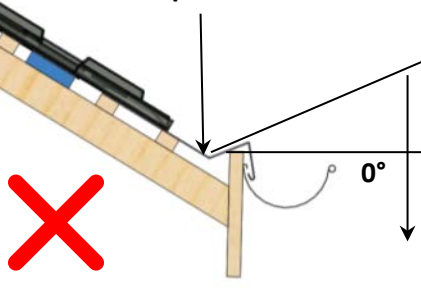
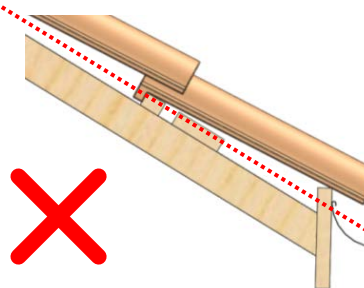
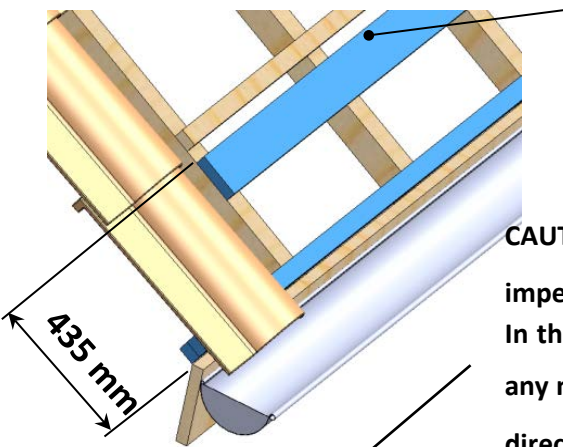

9.2.3) Specific position of the reference support batten for PV field at the gutter/eave

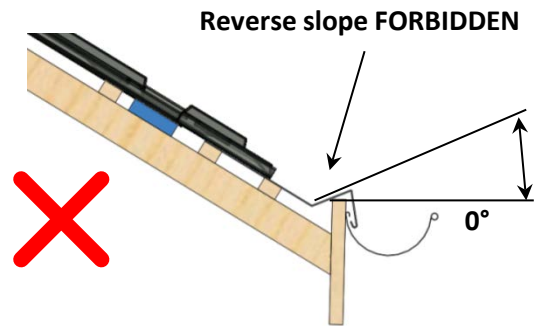
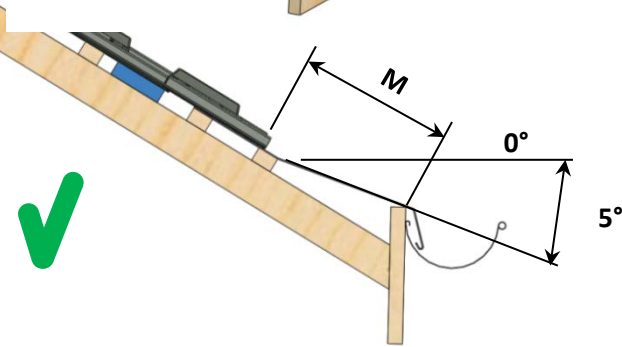
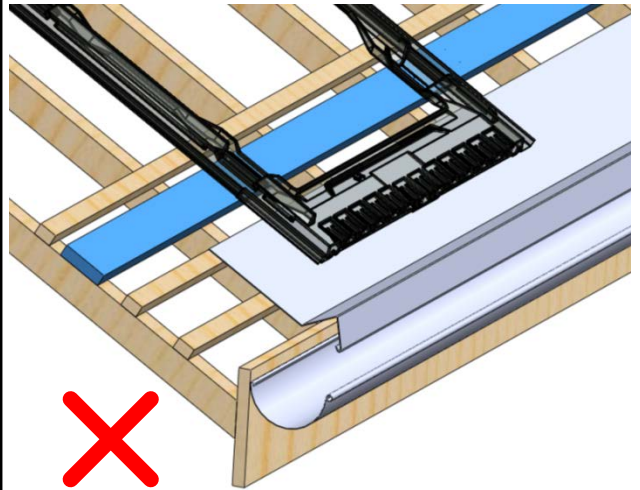
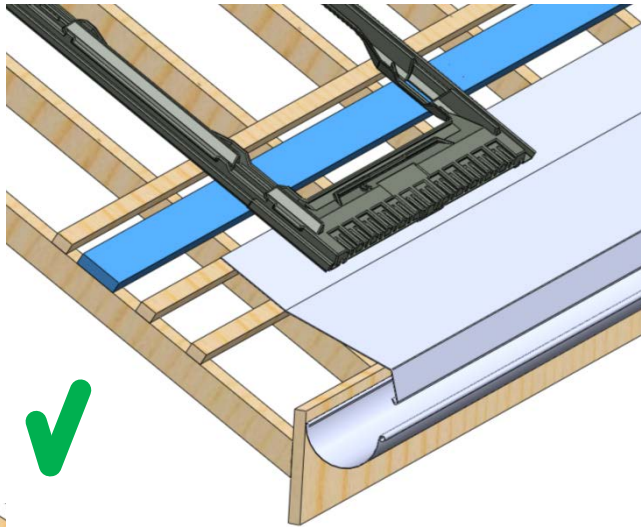

"M" to be measured on the roof by observing the conditions described here

Reference support batten(d)*

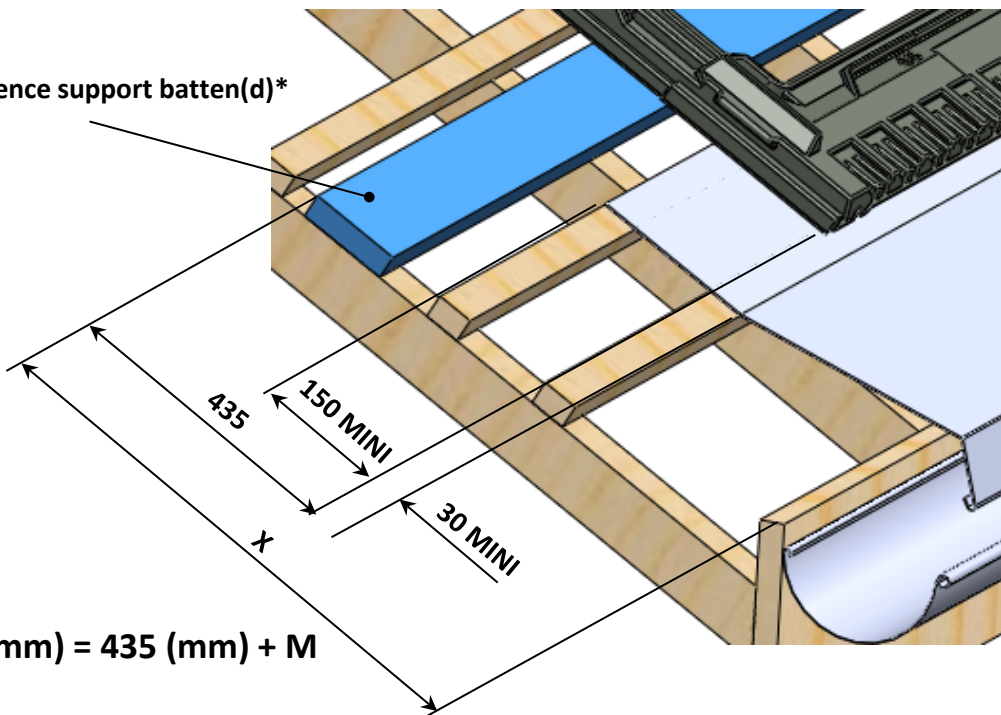

* Reference nomenclature

9.2.4) Installation of the bottom metal sheet

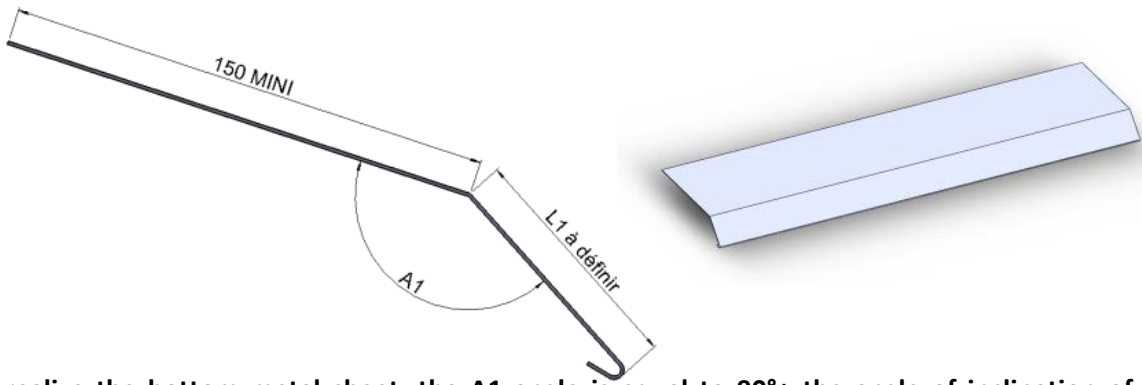

To realize the bottom metal sheet, the A1 angle is equal to $90^\circ +$ the angle of inclination of the roof.

Example: $A1 = 90^\circ + 30^\circ = 120^\circ$

the L1 dimension is defined by the position of the gutter. Define L1 so that the low end of the metal sheet is at least 20 mm in the sewer.

NOTE: this kind of metal sheet is applicable only for the PV field positioned at the gutter/eave. See paragraph 9.2.4 page 25.

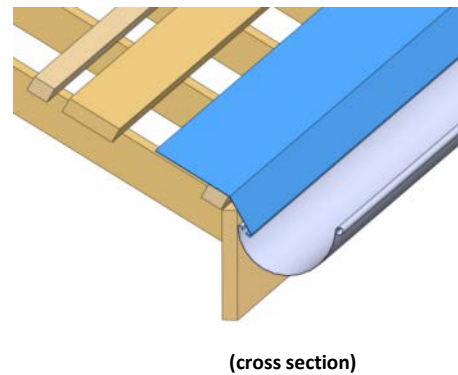
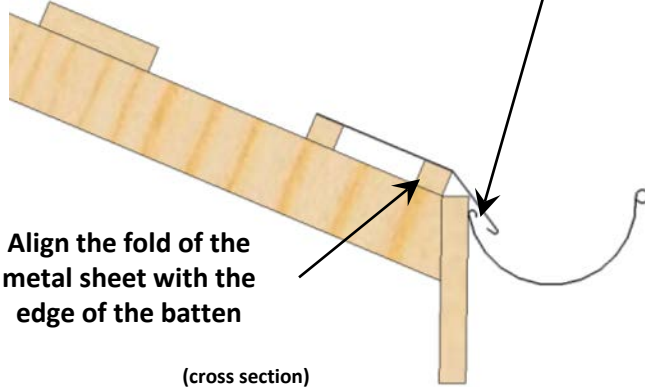

The length of the metal sheet can be variable. If it is needed to use several metal sheets, those will have imperatively to overlap of 100 mm MINI.

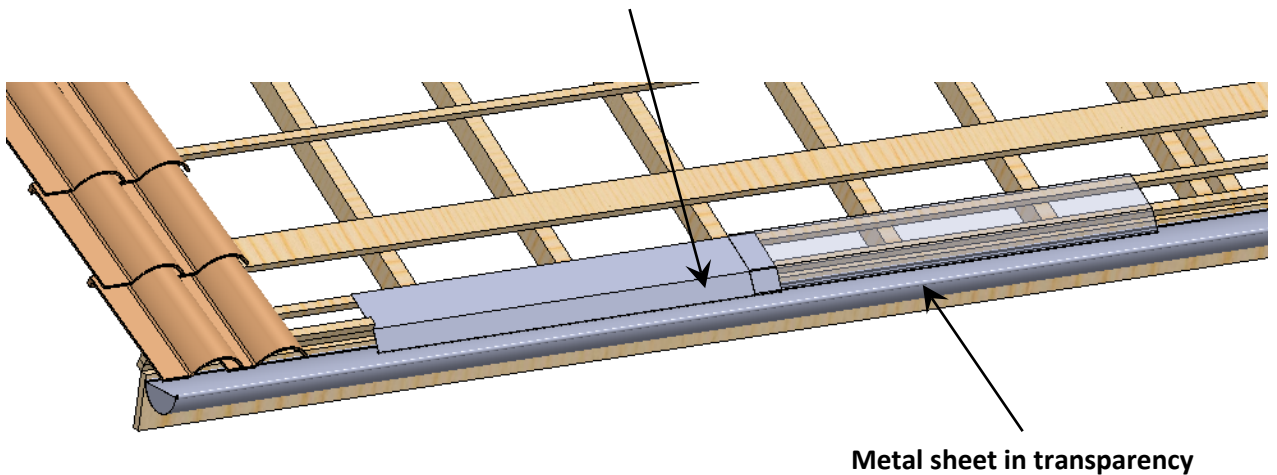

9.2.4) Installation of the bottom metal sheet

Add a batten or a support batten under the bottom metal sheet to support this one. This batten will at least make all the width of the PV field. The thickness of this batten will be identical to the thickness of the support batten (d)*.

* Reference nomenclature

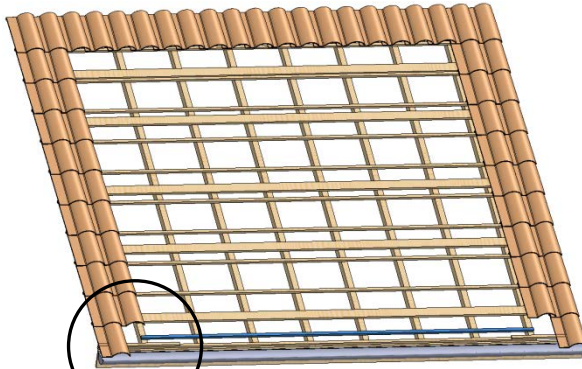

Align the batten with the higher edge of the bottom metal sheet

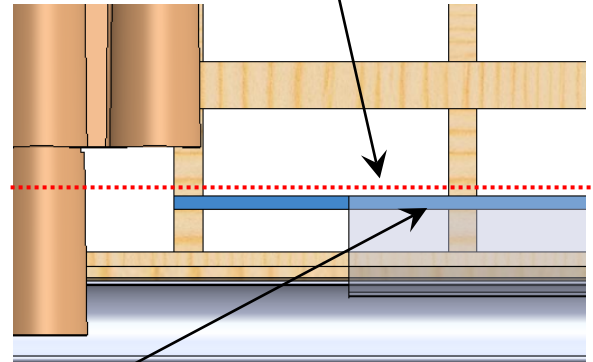
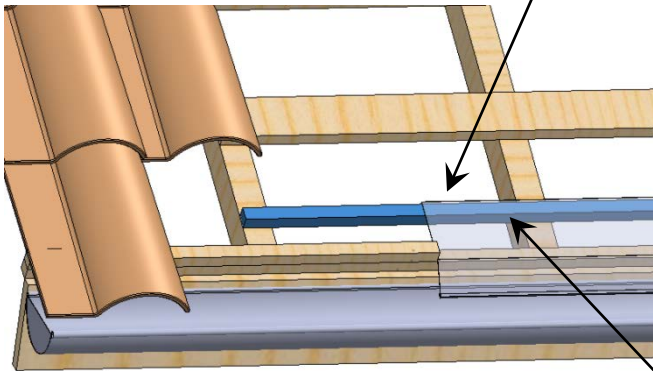

(View of top)

Bottom metal sheet in transparency

Set up and fasten the bottom metal sheet all over the width of the PV field. Fasten only the top part of the bottom metal sheet.

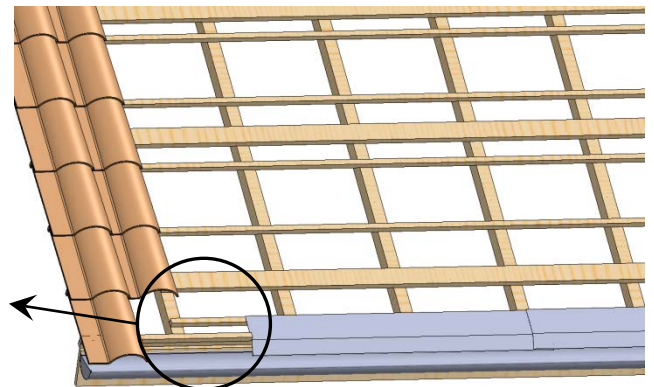
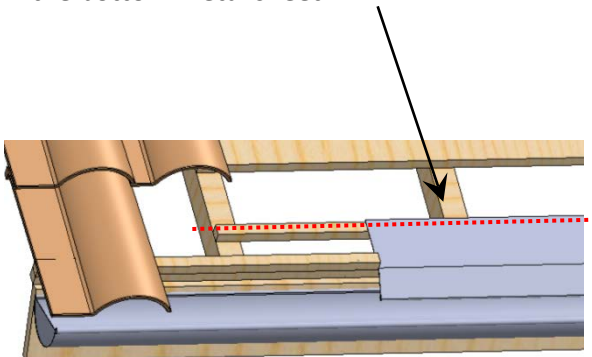

9.2.4)

Installation of the bottom metal sheet

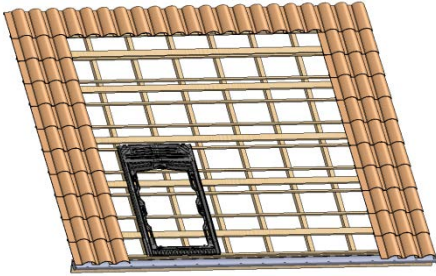

Replace the first tile at the lower left corner, Position the first frame (1) at a distance of 40 mm MAXIMUM of the edge of the tile

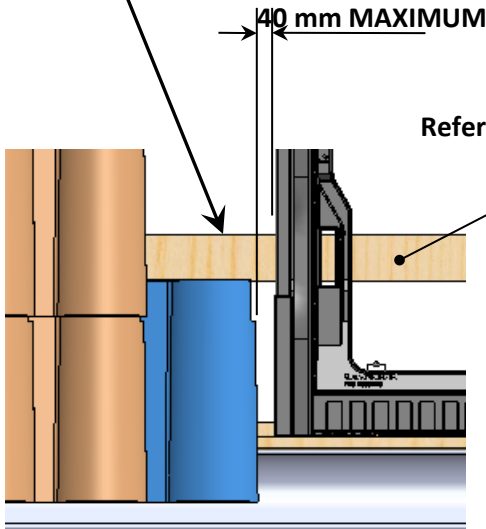
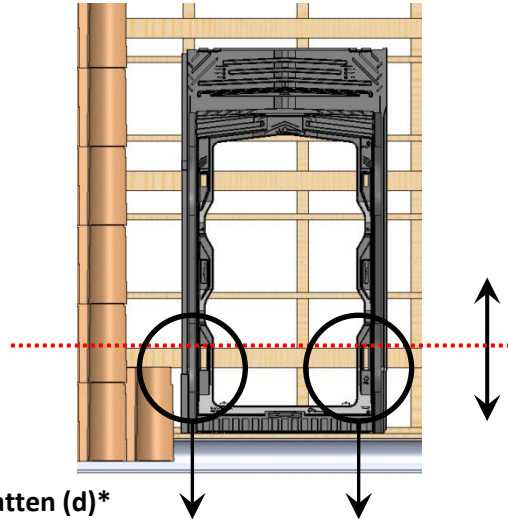

Position the frame (1) in the rake direction using two screws of Ø 5 placed in the openings indicated and put them leaning against the reference support batten (d)



DO NOT SCREW THESE SCREWS IN REFERENCE SUPPORT BATTEN. MUST REMOVE SCREWS BEFORE THE MOUNTING OF THE PV MODULES.

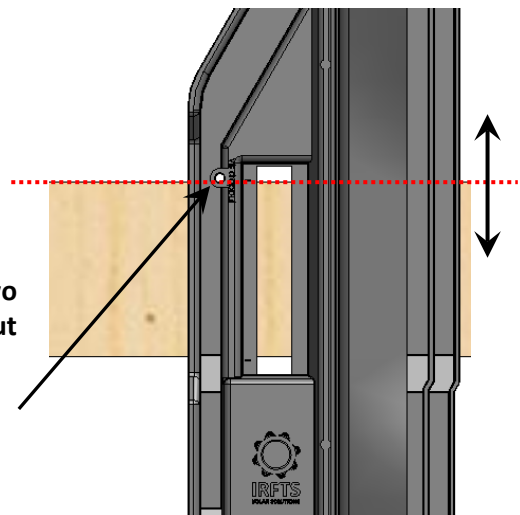

* Reference nomenclature

9.2.4) Installation of the bottom metal sheet

The bottom metal sheet must be aligned with the frames on each side of the PV field. Position all the frames of the first line while proceeding as indicated page 26. Do a marking at each end on the wood. Then slide the frames upward slightly.

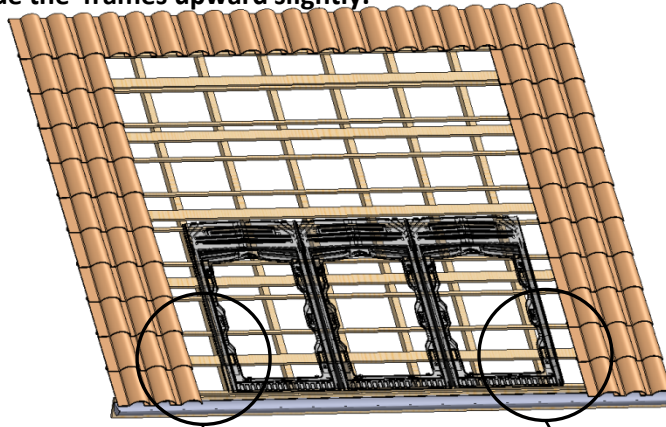

(view with fictitious frames)

Marking

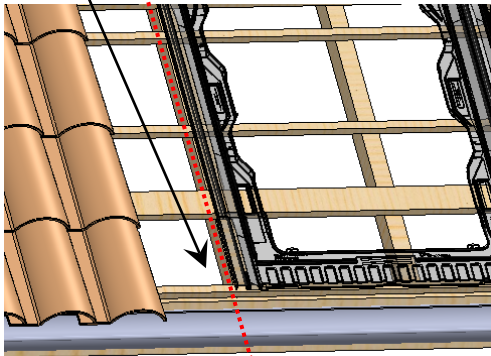

(view with fictitious frames)

Marking

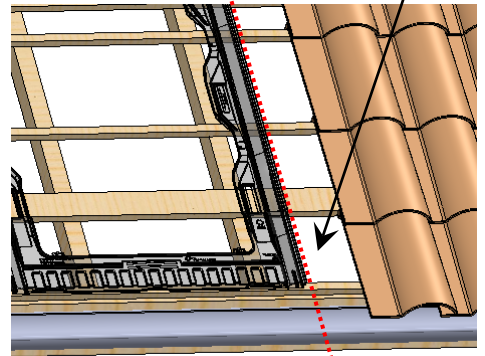

(view with fictitious frames)

Cut the top batten of the double lath 250mm wider than the marking so that the remaining batten is on the same level as the reference support batten.

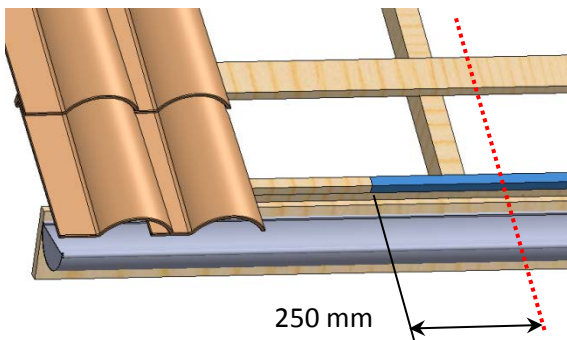

250 mm

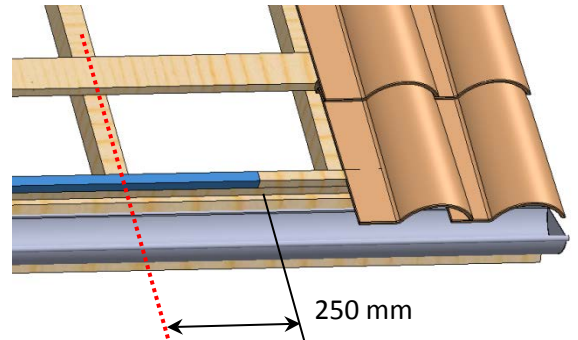

250 mm

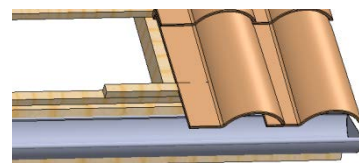
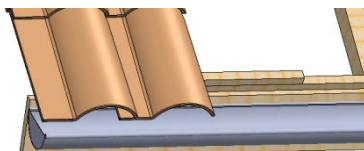

9.3) Flooring installation for all PV field installation

The length "L" of the support battens (d)* must imperatively make all the width of the PV field.
For the value "L" to see table page 12 of this document.

If needed, add to this dimension "L" a sufficient length on each side of PV field so that the ends of the batten lean on the rafter on both sides.

* Reference nomenclature

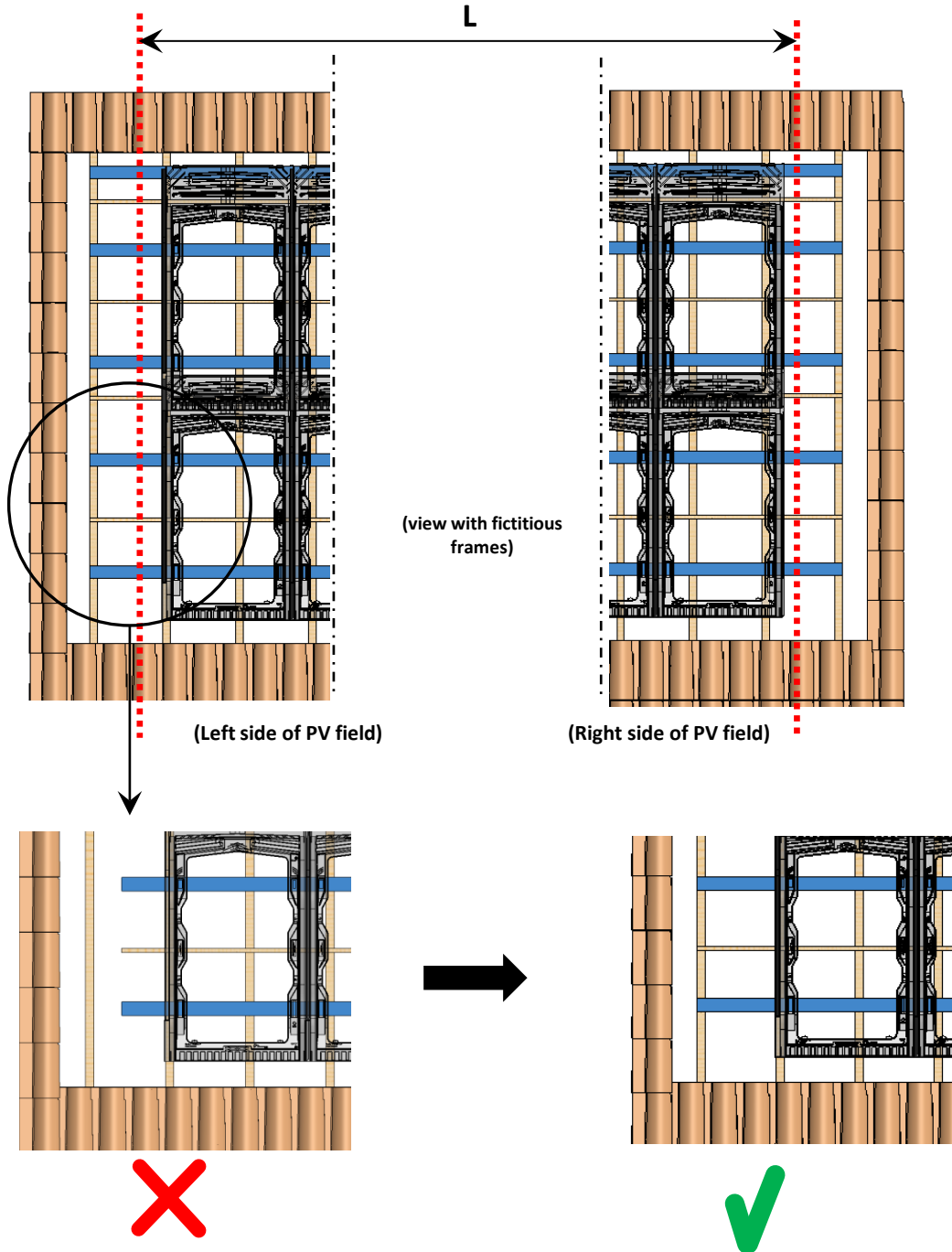

9.3) Flooring installation for all PV field installation

9.3.1) Flooring for an assembly with 6 fixings per module

Set up the horizontal flooring for the frames support with a number of support batten (d)* equal to (3 X no. vertical PV modules) + 1 at the top.

To screw the support batten follow the recommendations page 15 to 18 to know the type and the number of screws to be set up.

Step 1: Position and screw the first support batten 450 mm above the reference support batten (installed at the preceding Step).

Step 2: Position and screw another support batten 450 mm above the preceding one.

Step 3: Position and screw another support batten at the dimension E of the preceding one, for the value of E, see the table below.

Step 4: Position and screw another support batten 450 mm above the preceding one.

Step 5: Position and screw another support batten 450 mm above the preceding one.

Step 6: Repeat Steps 3.4 and 5 as many times as necessary up to the highest line of modules.

Step 7: ^{* Reference nomenclature} Position and screw the last support batten 620 mm a

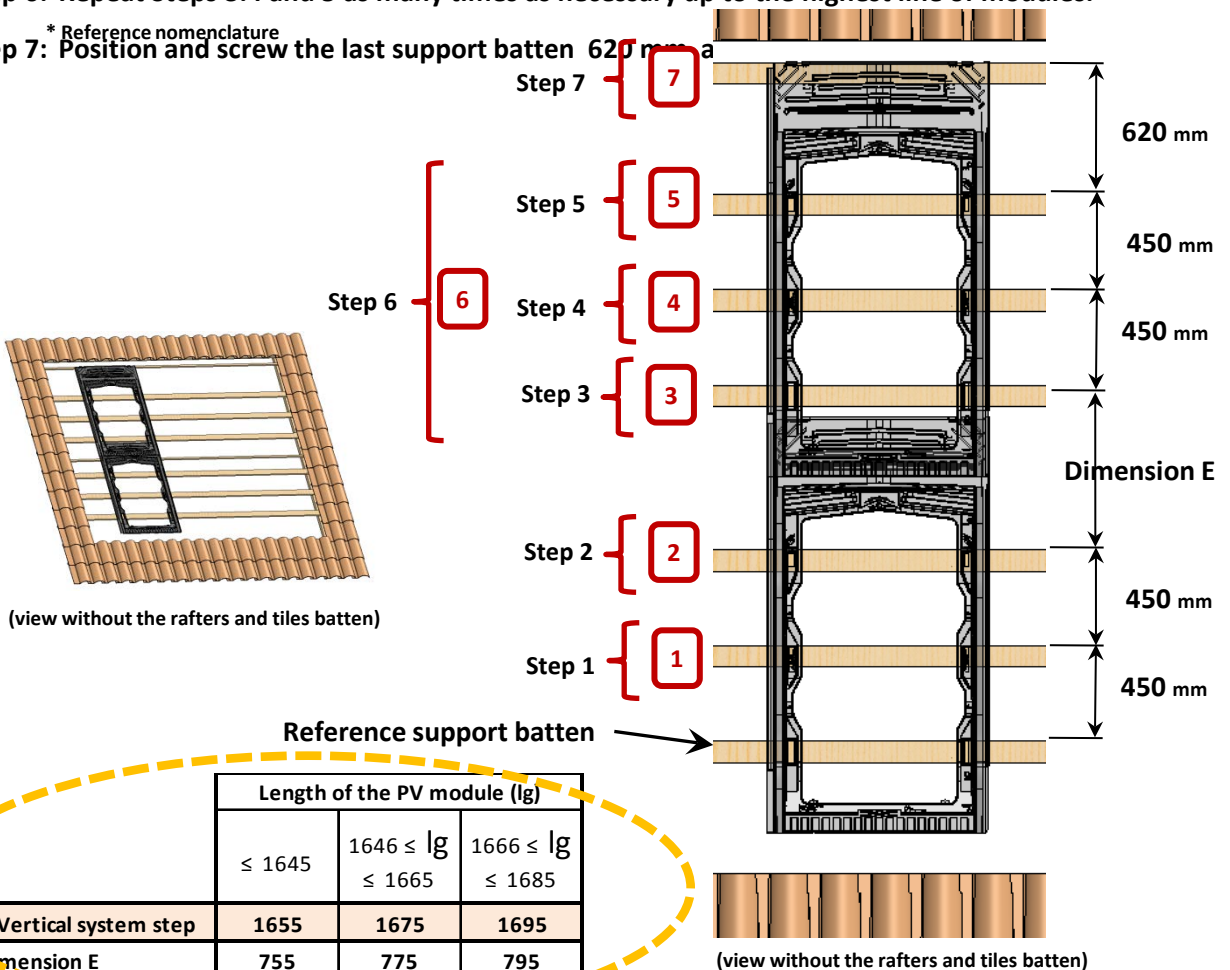

9.3) Flooring installation for all PV field installation

9.3.2) Flooring for an assembly with 4 fixings per module

Set up the horizontal flooring for the frames support with a number of support batten (d)* equal to (2 X no. vertical PV modules) + 1 at the top.

To screw the support batten follow the recommendations page 15 to 18 to know the type and the number of screws to be set up.

* Reference nomenclature

Step 1: Position and screw the first support batten 900 mm above the reference support batten (installed at the preceding Step).

Step 2: To position and screw another support batten at the coast E of the preceding one, for the value of E, see the table below.

Step 3: Position and screw another support batten 900 mm above the preceding one.

Step 4: Repeat Steps 2 and 3 as many times as necessary up to the highest line of modules.

Step 5: Position and screw the last support batten 620 mm above the preceding one.

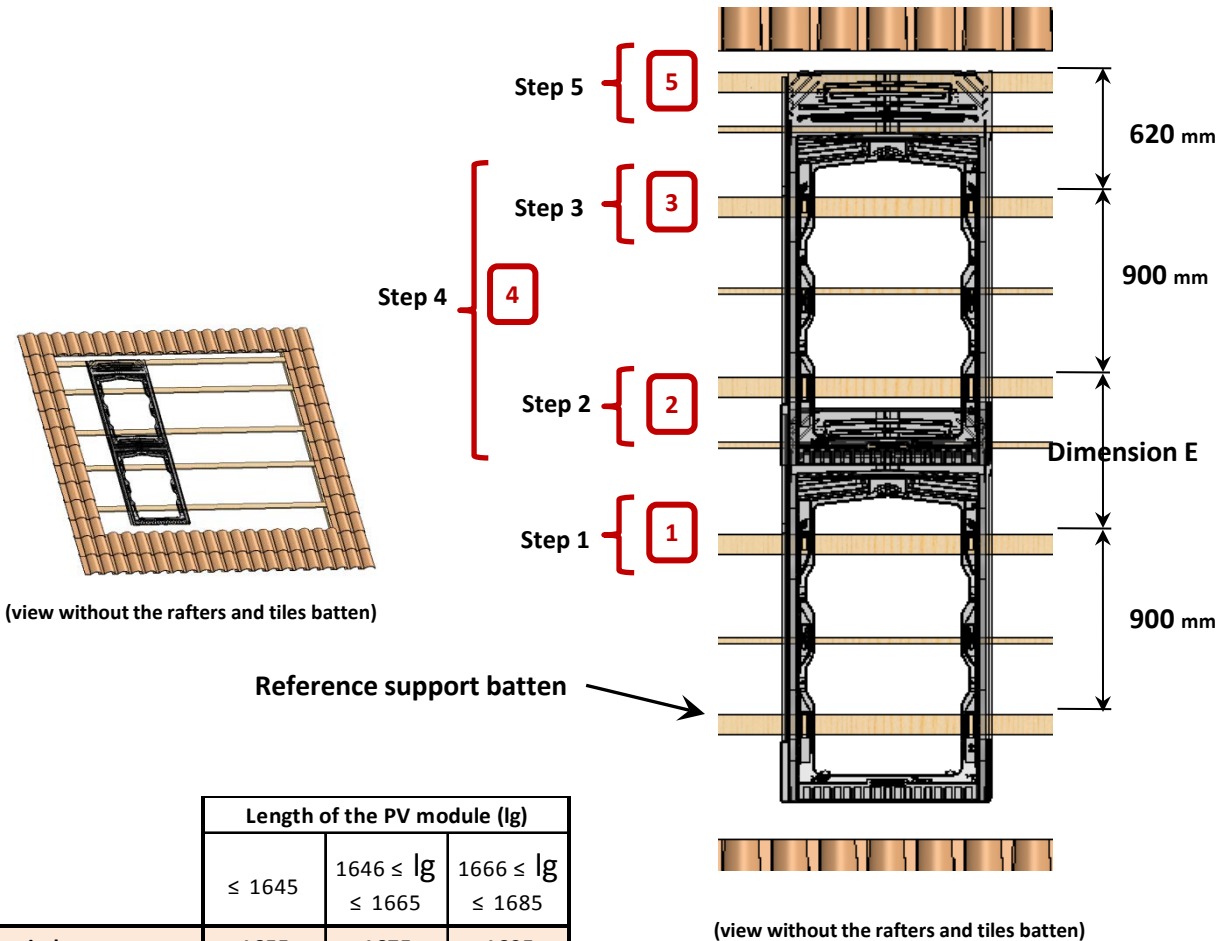

9.3.2) Flooring for an assembly with 4 fixings per module

On an assembly with 4 fixings per module, it is necessary to add and fix battens on each side of the PV field, with a thickness and width identical to the support batten (d)*. These battens will be used for the fixing of side flashings.

The battens must pass under the frame, to exceed this one of at least 200 mm MINI outside the PV field. For a roof without tiles battens, it is imperatively necessary to add a horizontal batten with a thickness identical to the support batten (d)* by line of frame, centered on the height of each line, over all the width of the PV field.

* Reference nomenclature

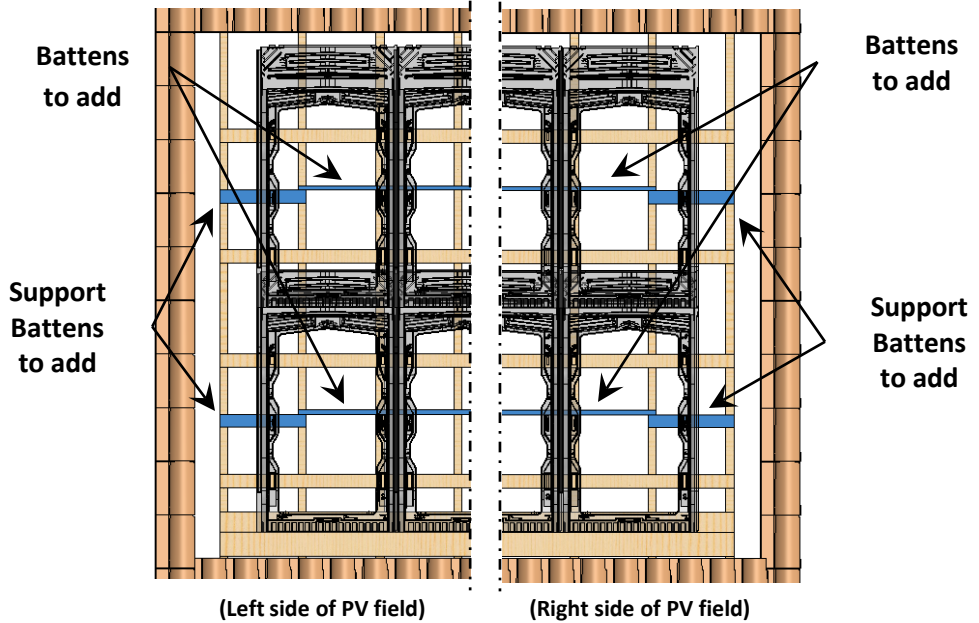

200 mm MINI

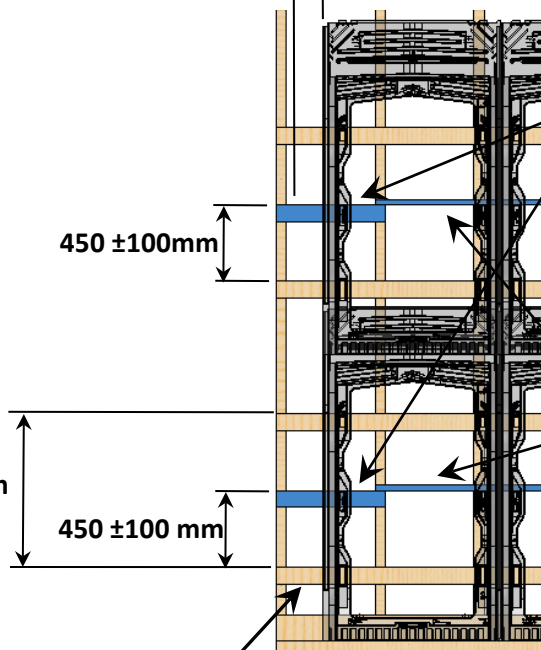

1°) Position and screw a support batten at 450 mm ±100 from the preceding one in each interval of 900 mm

2°) If necessary according to the recommendations, position and screw the battens all over the width of the PV field leaning against the battens previously posed.

Reference support batten (view without the tiles batten)

9.3.3) Installation of leaning batten

To ensure a good support where the frames overlap it is necessary to set up and to fix a horizontal batten every three support battens (d)* for the assemblies with 6 fixings, every 2 support battens (d)* for the assembly with 4 fixings.

If no tiles battens exists in the zones described below, add battens all over the width of the PV field.

Those battens will have the same thickness as the support batten(d)*. Position at 300 ± 100 mm of the lower support batten.

It is imperative to make this operation for all the lines of frame of the PV field.

* Reference nomenclature

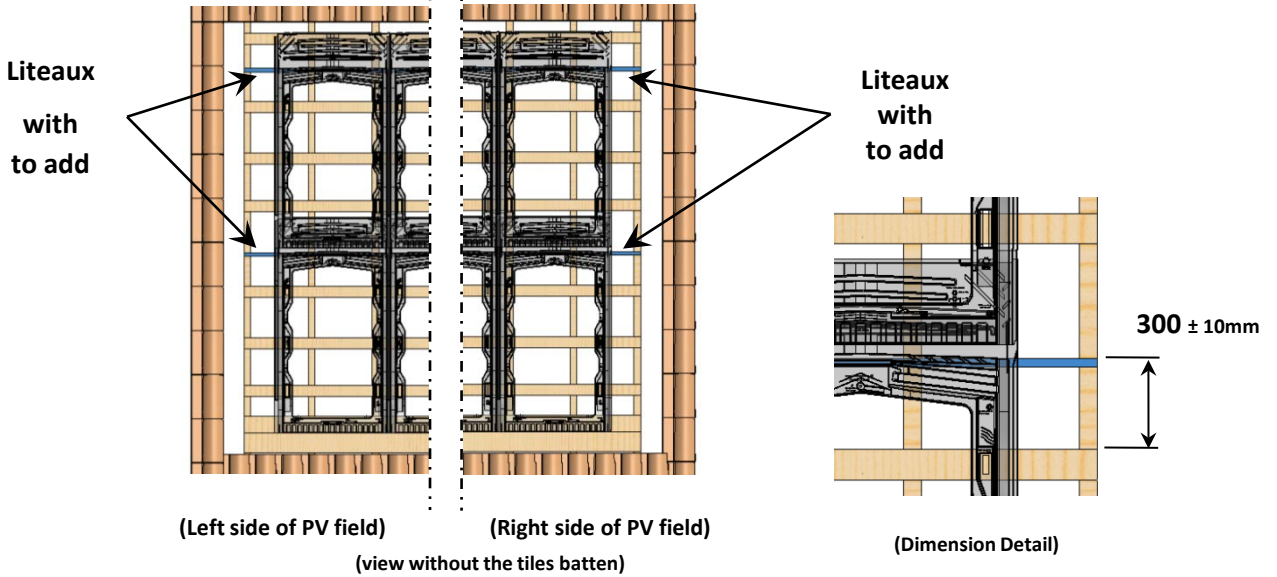

Flooring with 4 fixings per PV module

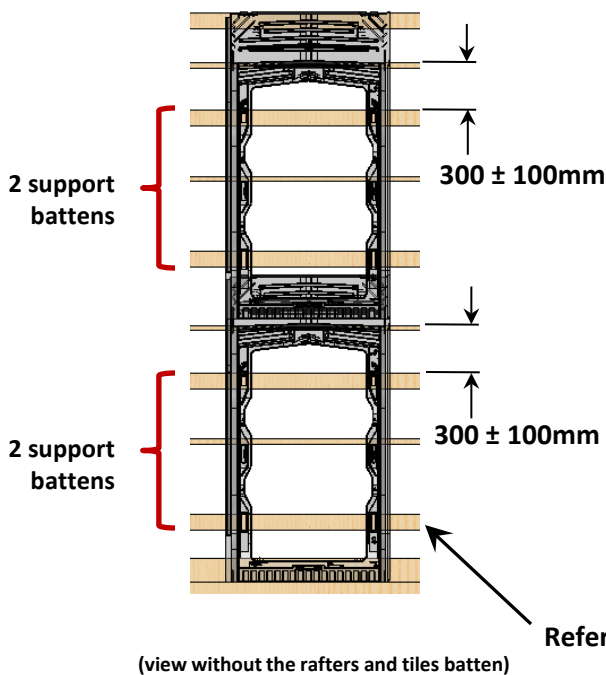

Flooring with 6 fixings per PV module

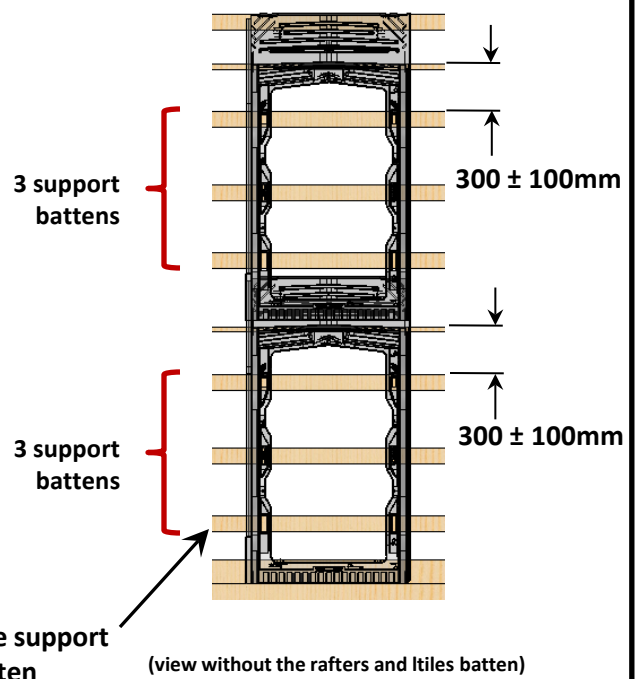

Reference support batten

9.4)

Installation of system EASY-ROOF

This section of the installation manual relates to all kind of installation (middle of the rake or at the gutter)

9.4.2)

Installation of the EASY-ROOF system

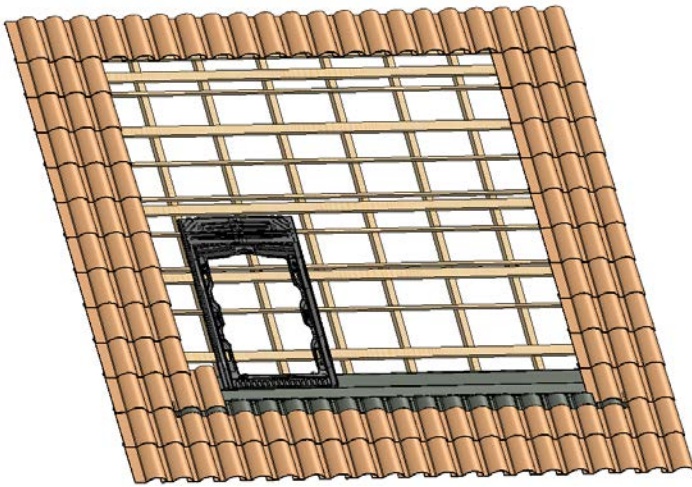

Replace the first tile with the left lower corner, Position the first frame (1) at a distance of 40 mm MAXIMUM of the edge of the tile.

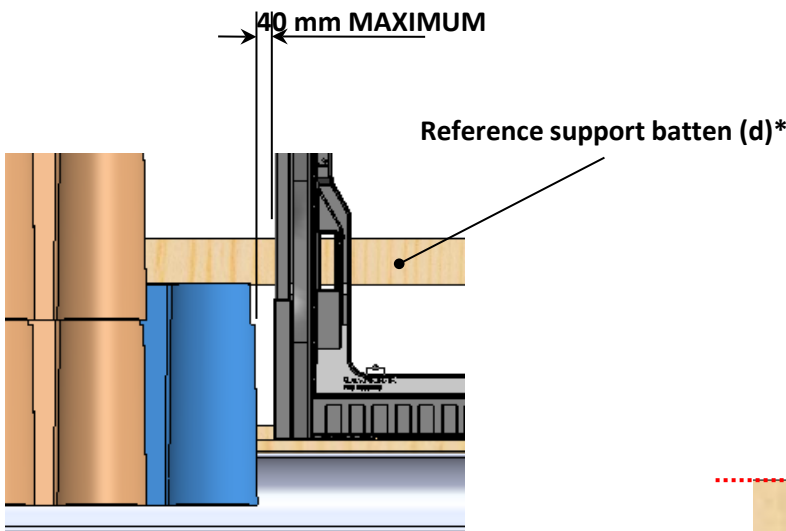
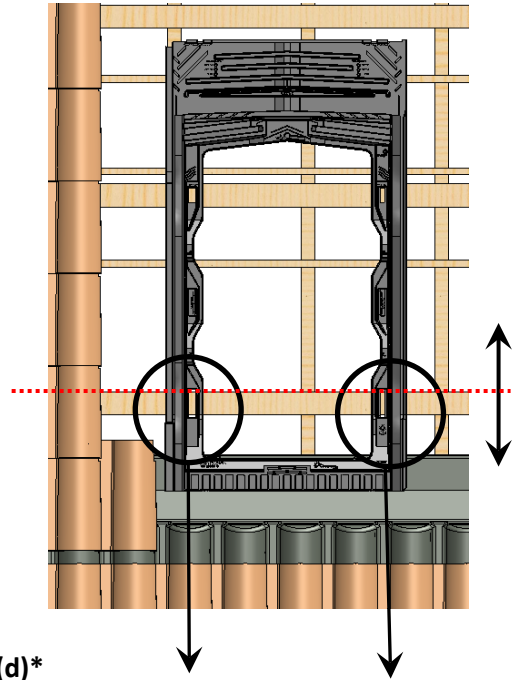

Position the frame (1) in the rake direction using two screws of Ø 5 placed in the openings indicated and put them leaning against the reference support batten (d).



DO NOT SCREW THESE SCREWS IN REFERENCE SUPPORT BATTEN. MUST REMOVE SCREWS BEFORE THE MOUNTING OF THE PV MODULES.

* Reference nomenclature

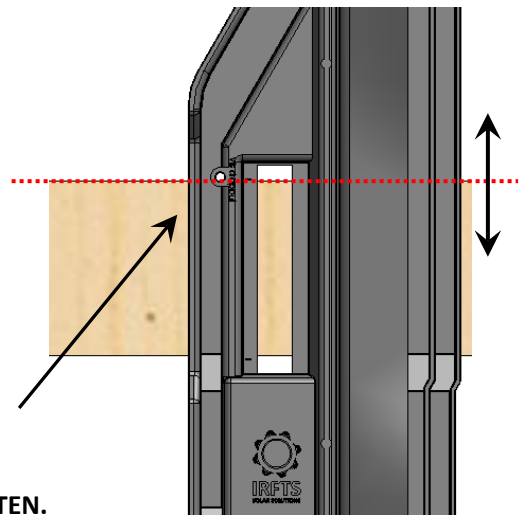

9.4.2)

Installation of the EASY-ROOF system

1°) Set up and interlock another frame above the precedent. Align them perfectly in the vertical direction. (do a marking with the chalk line)

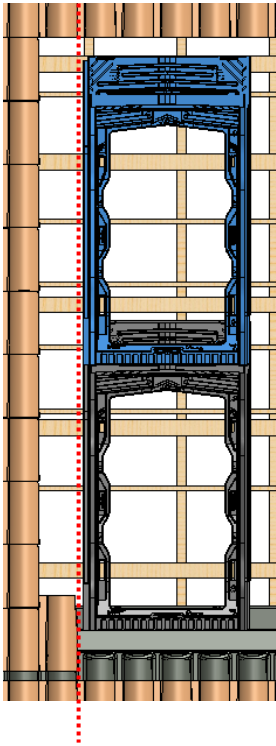

2°) Adjust the vertical step between the frames according to the length of the PV modules. Use one of the three preset indexings on each side of the frame.

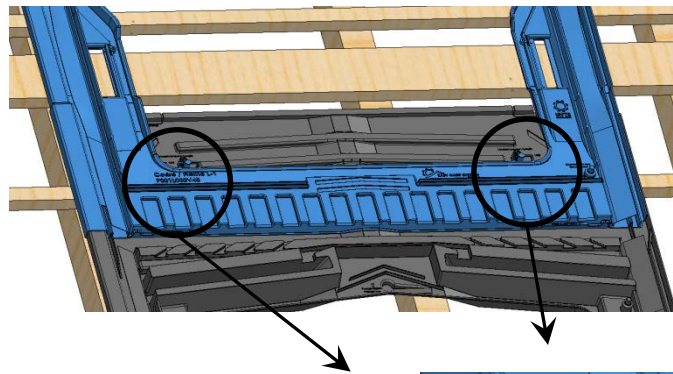
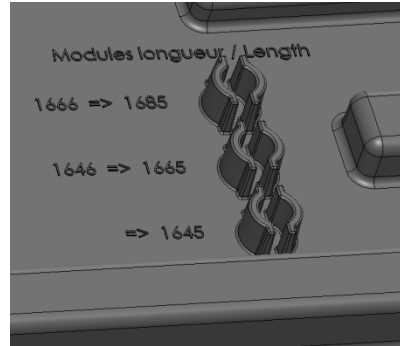

3°) Set up another frame on the first line. Align this one on the reference support batten as indicated page 34.

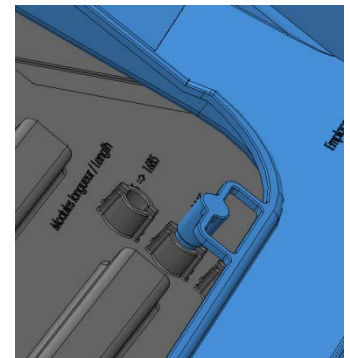
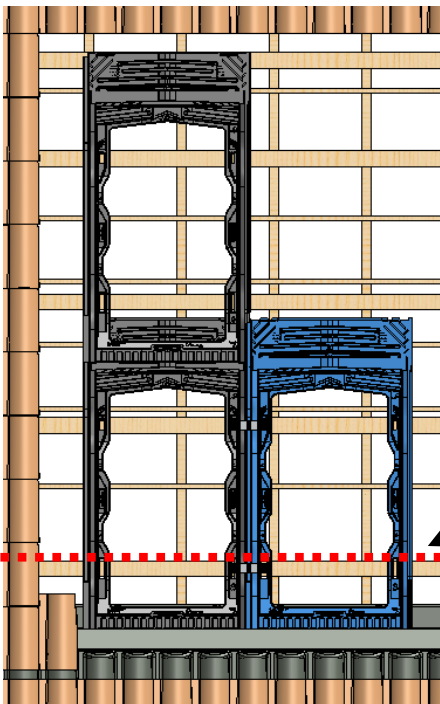

Reference support batten (d)*

* Reference nomenclature

9.4.2)

Installation of the EASY-ROOF system

1°) Place two mounting tool (13) on the two bottom frames as shown on the drawing. Two sets of mounting tools (13) at least will be necessary to mount the system.

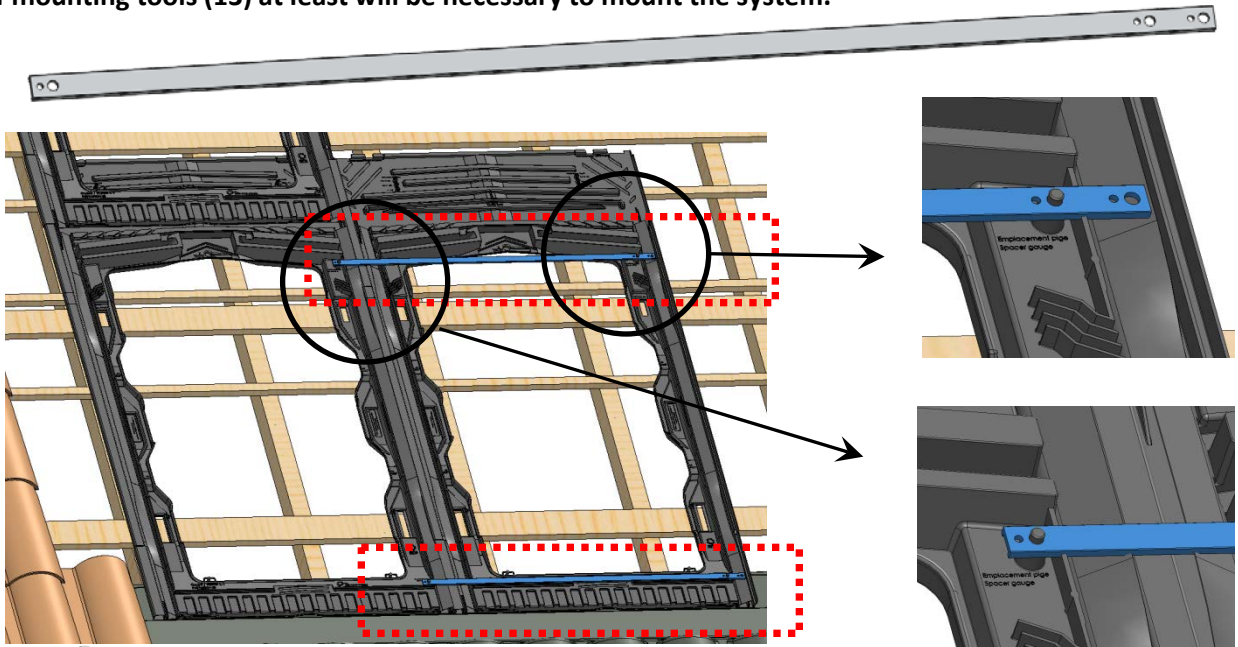

THE USE OF THE MOUNTING TOOL (13) IS MANDATORY TO ASSEMBLE ALL THE SYSTEM.

2°) Place the superior and inferior middle bracket (7) and screw with screws 6x40 STAINLESS (9).

Do Not put the other fixings immediately. This operation will be carried out later.

DO NOT REMOVE THE MOUNTING TOOL (13) IMMEDIATELY.

NOTE: also mount the central middle clamp (7) for an assembly with 6 fixings.

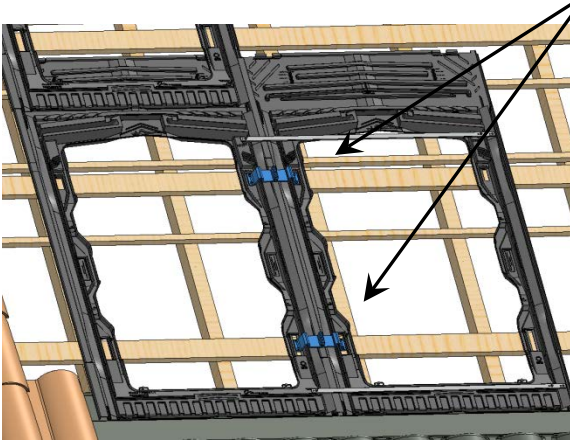

Center the bracket in the vertical direction in the positioning hole (for dilation)



3°) If grounding is not done by connecting the ground wire directly to PV module, carry out this connection by connecting a ground wire on the middle brackets (7). This way it grounds two PV modules. Connect only one mounting bracket by PV module. Carry out this connection each second modules for each line of module.

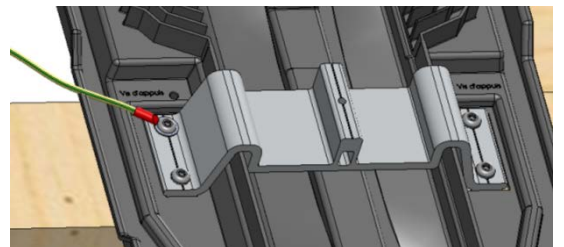

9.4.2)

Installation of the EASY-ROOF system

- 1°) Set up and interlock another frame on the first line on the right of the precedent. Align this one on the reference support batten as indicated page 34.
- 2°) Set up and interlock another frame on the second-row on the right of precedent.
- 3°) Adjust the vertical step between the frames using one of the three preset indexings on each side of the frame as done with the precedent frame.

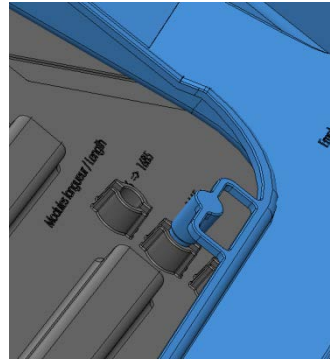
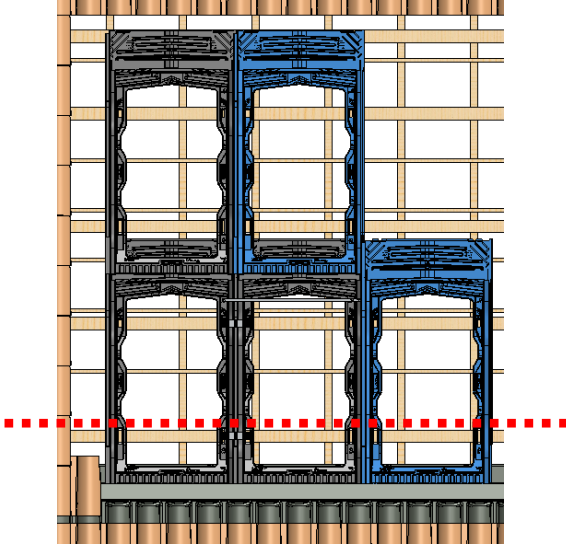

- 4°) Place two other mounting tool (13) on the two top frames as shown on the drawing.

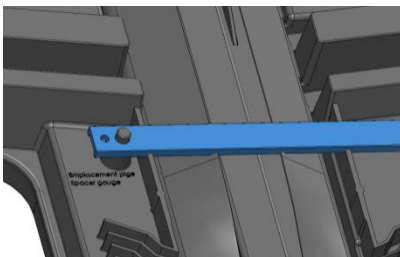
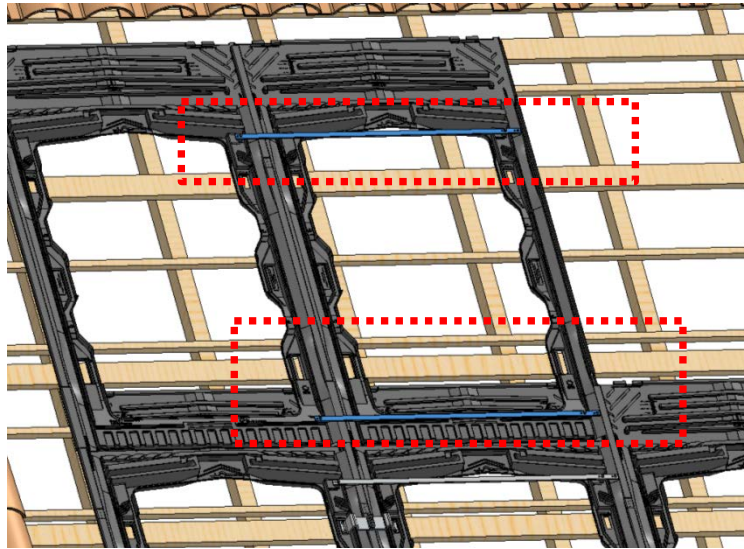

9.4.2)

Installation of the EASY-ROOF system

5°) Place the superior and inferior middle bracket (7) and screw with screws 6x40 STAINLESS (9). Do not put the other fixings immediately. This operation will be carried out later. Do not forget the grounding.

NOTE: also mount the central middle clamp (7) for an assembly with 6 fixings.

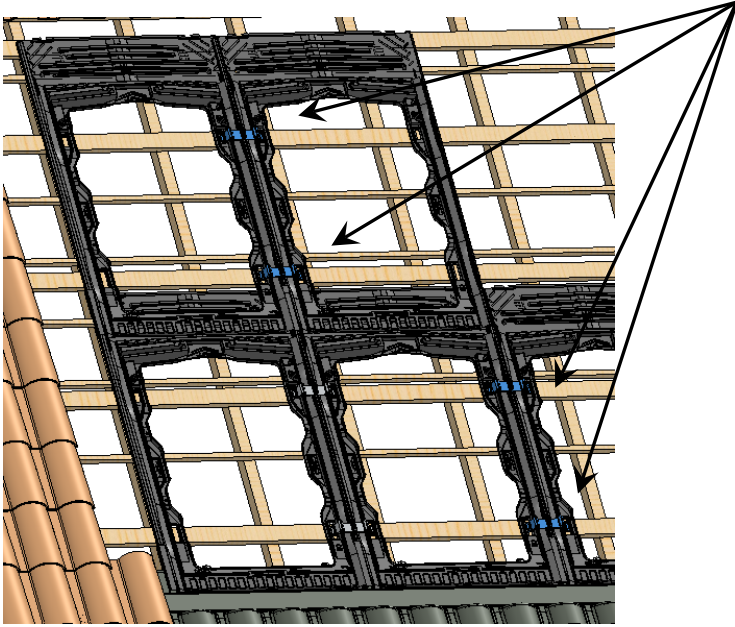

6°) Move the mounting tool (13) from the bottom line to the right.

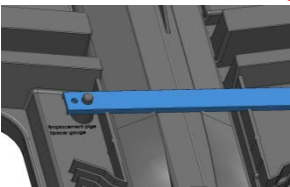
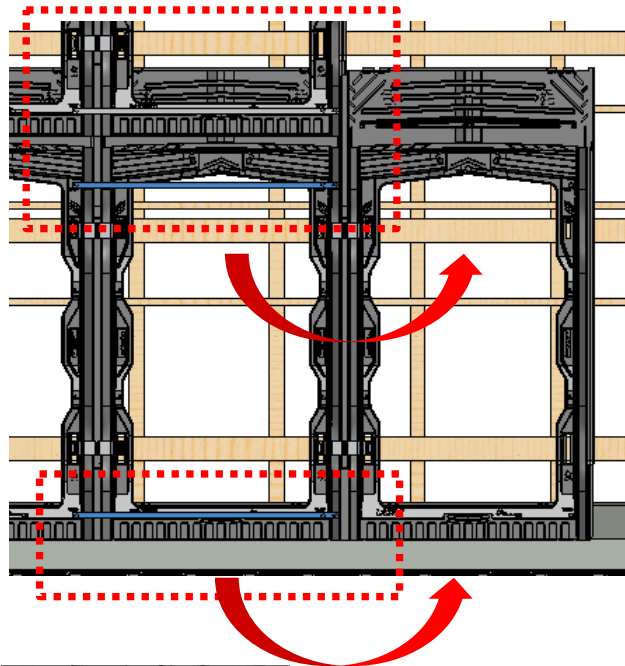

THE MOUNTING TOOL (13) COULD BE MOVED ONLY IF THE 4 (OR 6) MIDDLE BRACKETS ARE MOUNTED.

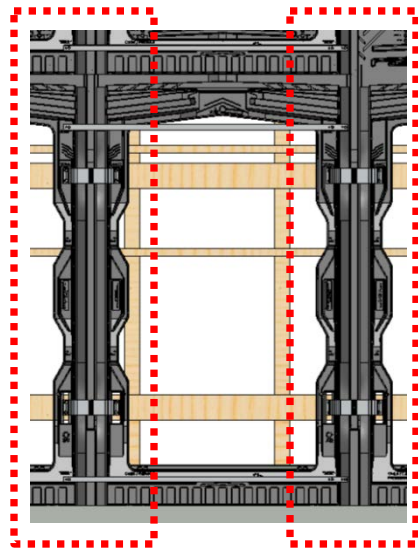

9.4.2)

Installation of the EASY-ROOF system

7°) Set up and interlock all the other frames of the PV field by repeating the operations of pages 35 to 38.

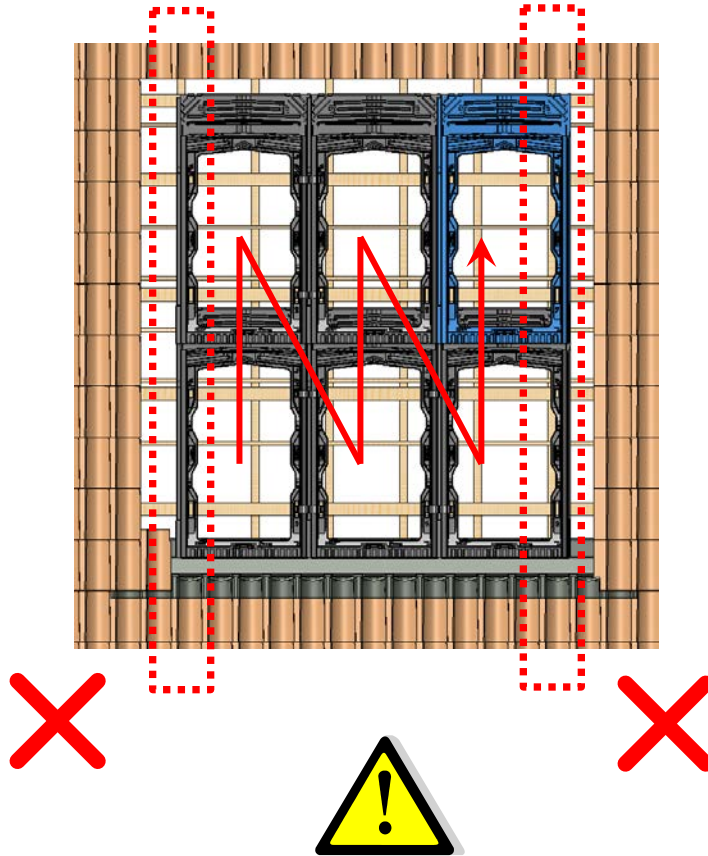

**DO NOT PUT IN PLACES THE END BRACKET ON THE SYSTEM,
THIS OPERATION WILL BE CARRIED OUT LATER AFTER THE
POSE OF THE SIDE FLASHING.**

9.4.3)

Installation of system EASY-ROOF

1°) Position the first left flashing beside the first frame.

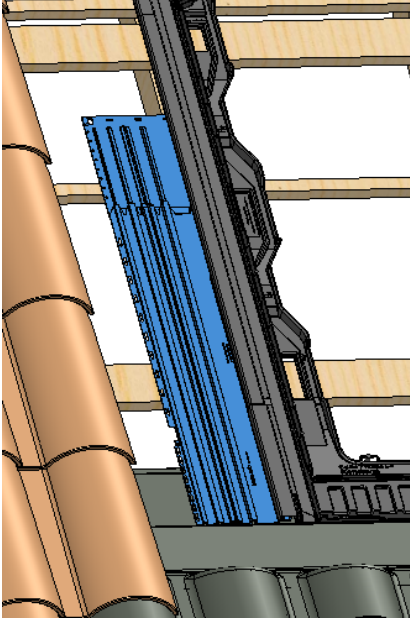

2°) Set up the others one, they interlock each other (See opposite).

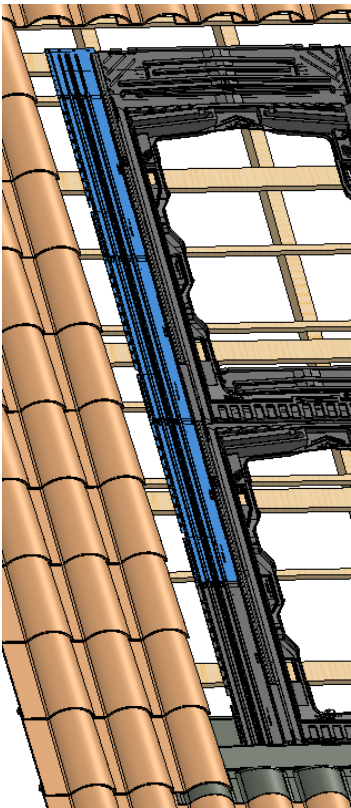

Flashings assembly

a°) Interlock the pin of the second flashing in the first one.

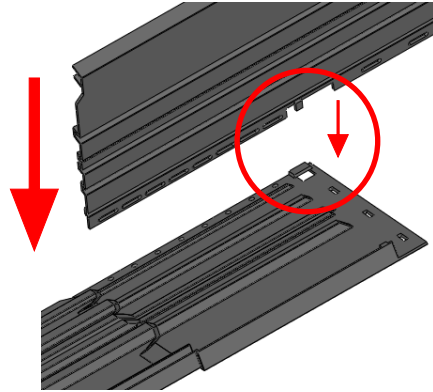

b°) Rotate the second flashing.

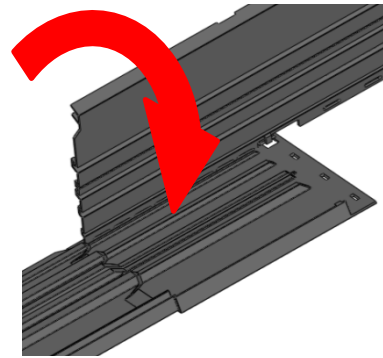

c°) Clip the second flashing with the other.

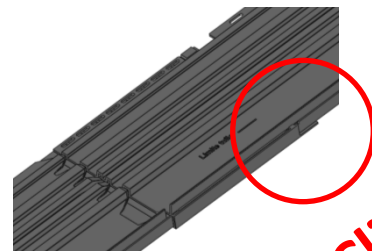

d°) Optional : Clip the frieze support at the top of the last flashing.

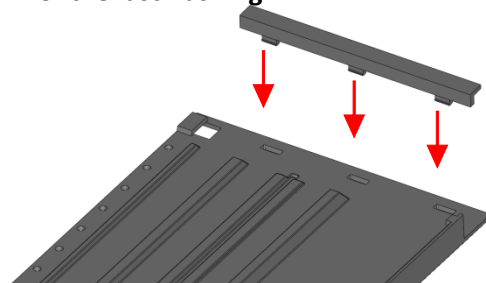

9.4.3)

Installation of the EASY-ROOF system

3°) Slightly lift the frames on the left, to drag the row of flashings under the frames.

4°) Align the last flashing with the top of the frame.

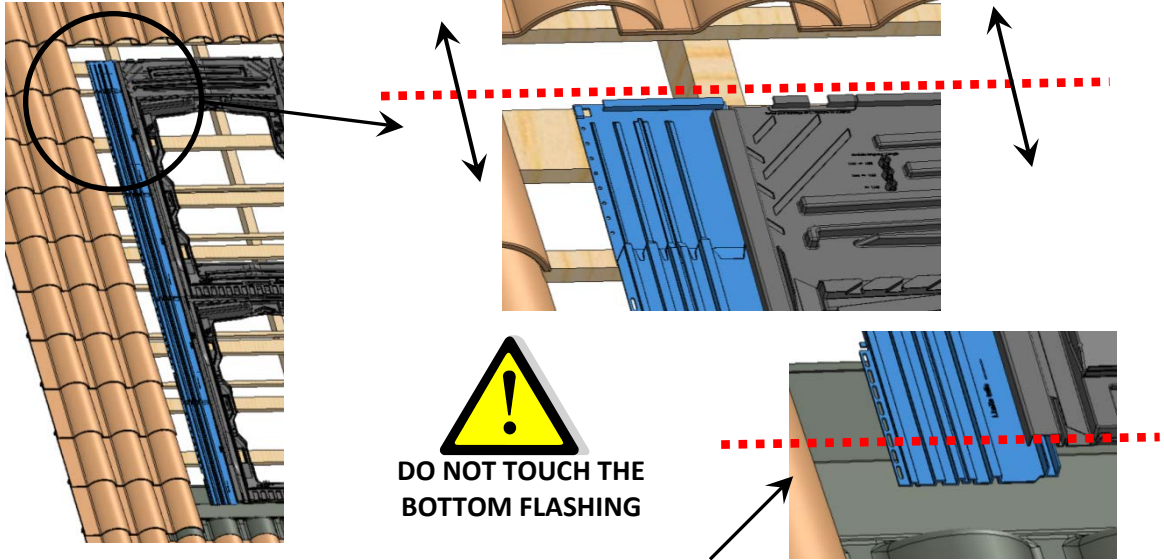

5°) At the bottom of the field cut the part of flashing which exceeds the frame if necessary.

6°) Set up a screw convex head 5x30 stainless (b) at each flashing overlap. Screw moderately.

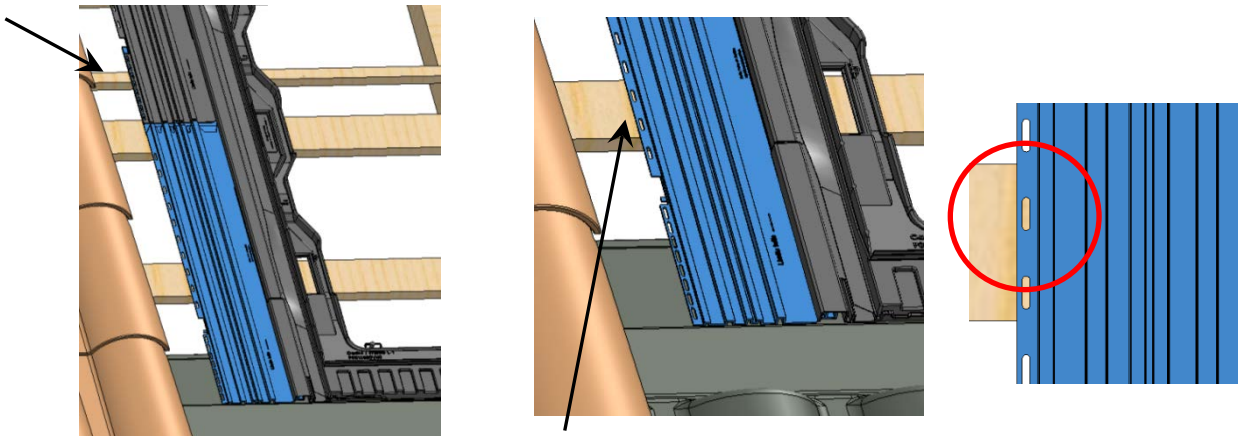

7°) Set up a screw convex head 5x30 stainless (b) centered on the oblong hole. Screw moderately. **VERY IMPORTANT**, to unscrew one turn, that is useful for the dilation of the part.

8°) If there is no batten under the flashings overlap, add a batten under the overlap.

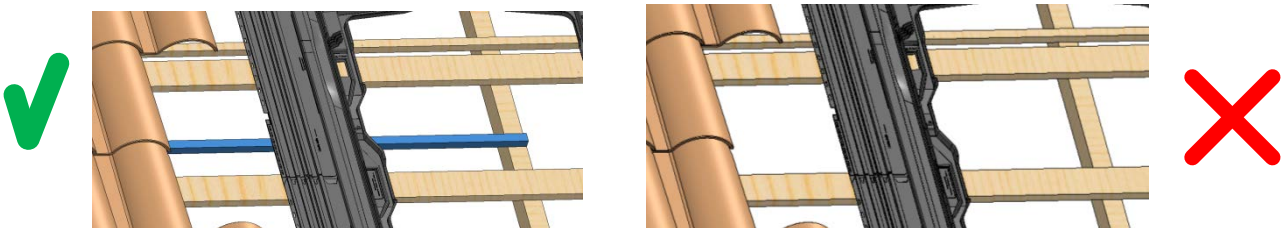

9°) Fix all left flashings by applying instructions 6.7 and 8.

9.4.4)

Installation of the EASY-ROOF system

1°) Position the first right flashing beside the first frame.

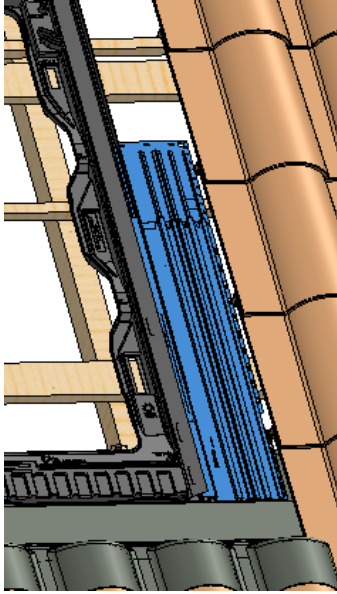

2°) Set up the others one, they interlock each other (See opposite).

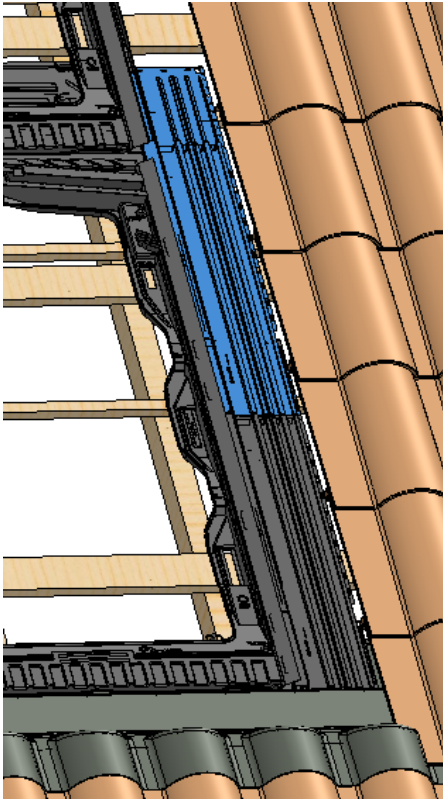

Flashings assembly

a°) Interlock the pin of the second flashing in the first one.

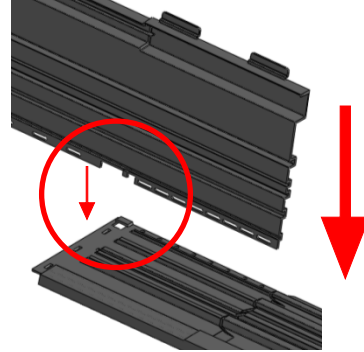

b°) Rotate the second flashing.

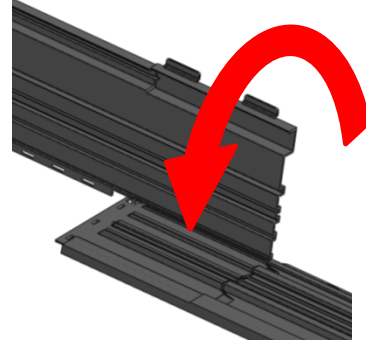

c°) Clip the second flashing with the other.

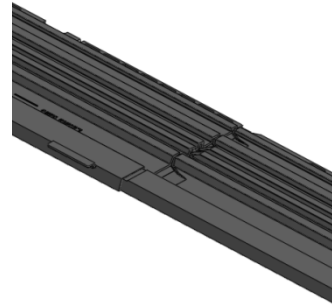

d°) Optional : Clip the frieze support at the top of the last flashing.

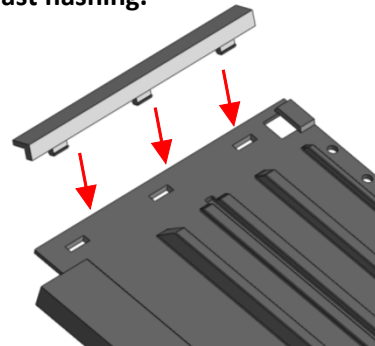

9.4.4)

Installation of the EASY-ROOF system

3°) Align the last flashing with the top of the frame. Place the ears of the flashings under the flexible flap of the frames.

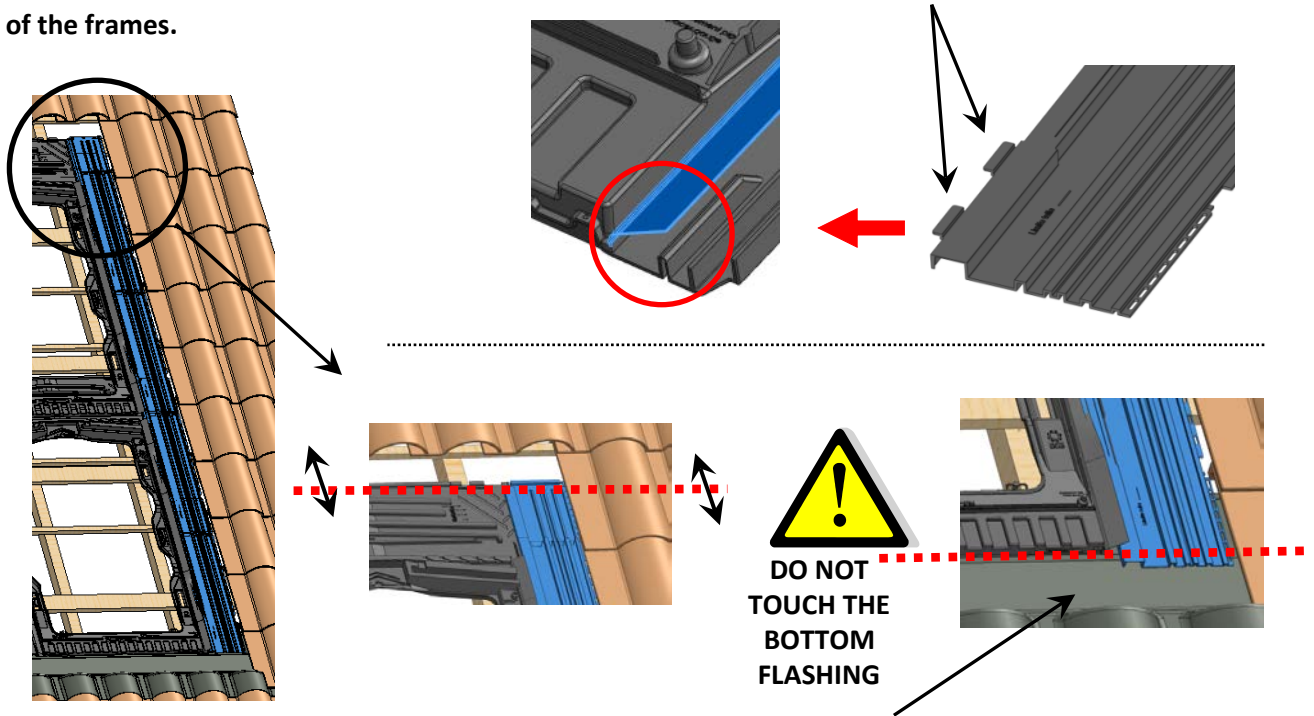

4°) At the bottom of the field cut the part of flashing which exceeds the frame if necessary.

5°) Set up a screw convex head 5x30 stainless (b) at each flashing overlap. Screw moderately.

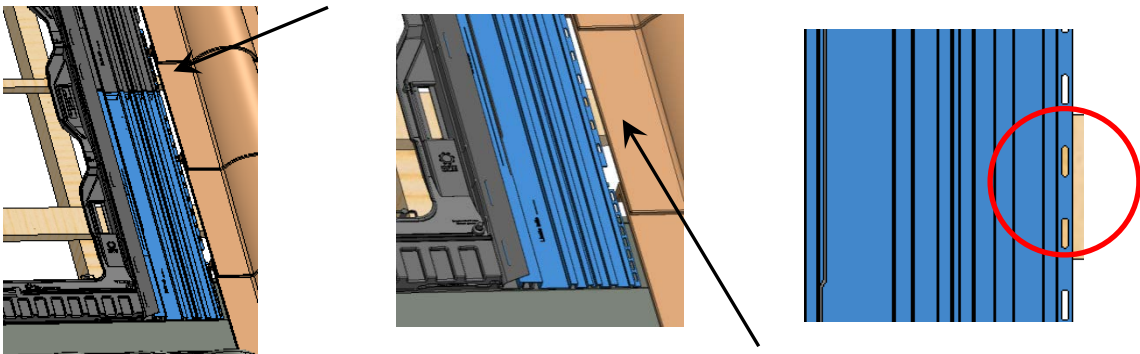

6°) Set up a screw convex head 5x30 stainless (b) centered on the oblong hole. Screw moderately. VERY IMPORTANT, to unscrew one turn, that is useful for the dilation of the part.

7°) If there is no batten under the flashings overlap, add a batten under the overlap.

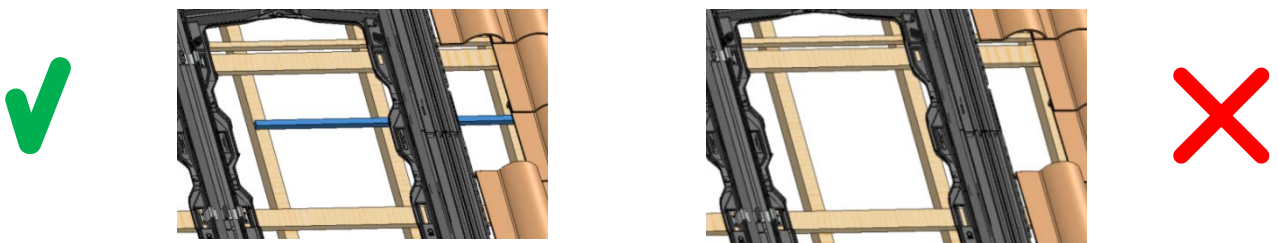

8°) Fix all right flashings by applying instructions 5.6 and 7.

9.4.5)

Installation of the EASY-ROOF system

- 1° Set up all the end bracket (8) on the right of PV field. Interlock each end bracket in the openings on the frames.
- 2 or 3 end bracket (8) per frames according to the technical recommendations.
- Screw with screws 6x40 STAINLESS (9).

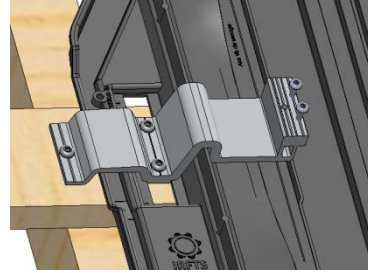
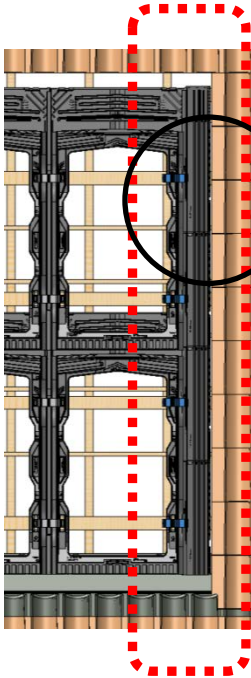

Center the bracket in the vertical direction in the positioning hole (for dilation)

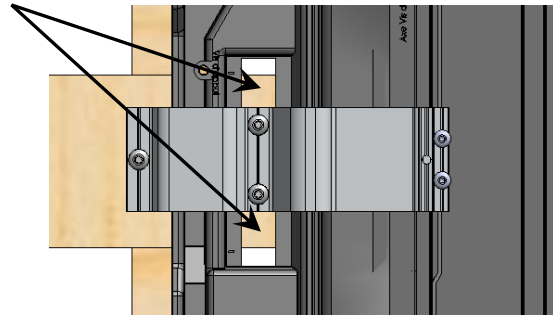

9.4.5)

- 1° Set up all the end bracket (8) on the left of the PV field using a mounting tool (13) according to the procedure describes hereafter.

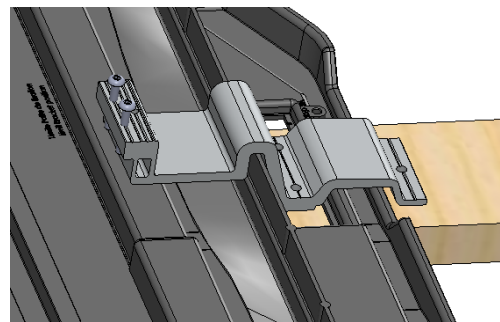
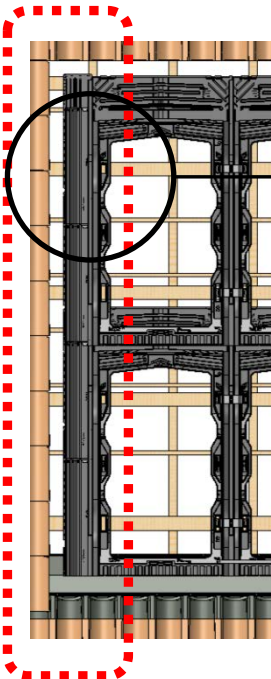

THE USE OF A MOUNTING TOOL IS MANDATORY FOR THE INSTALLATION OF THE END BRACKET ON THE LEFT SIDE OF THE PV FIELD.

9.4.5)

Installation of the EASY-ROOF system

- 1°) Fix one end of the mounting tool (13) on the middle bracket of the same frame using a screw CHc M6 (11 or 12). Screw some threads only.
- 2°) Position an end bracket (8) in the opening on the frame.
- 3°) Fix the other end of the mounting tool (13) on the end bracket (8) using a screw CHc M6 (11 or 12). Screw some threads only.
- 4°) Align the end bracket (8) with the mounting tool (13).
- 5°) Screw the end bracket (8) with screws 6x40 STAINLESS (9).
- 6°) Remove the mounting tool (13).
- 7°) Carry out the pose of all other end bracket (8) on the left side of the PV field by repeating the operations from 1 to 6.

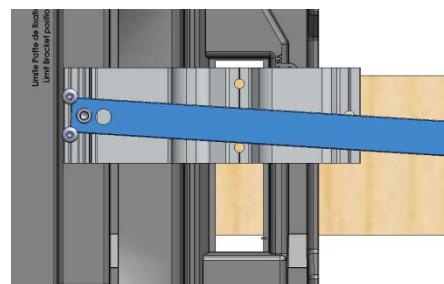
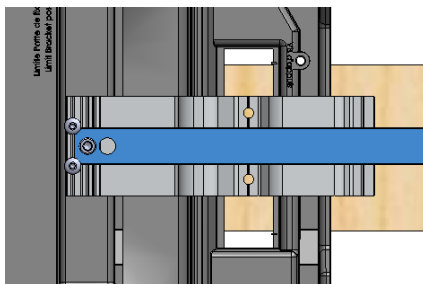
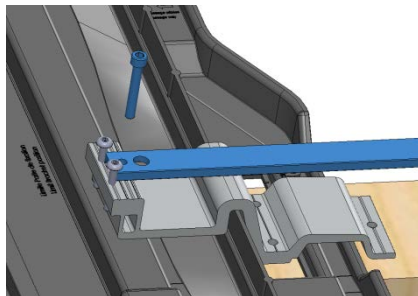
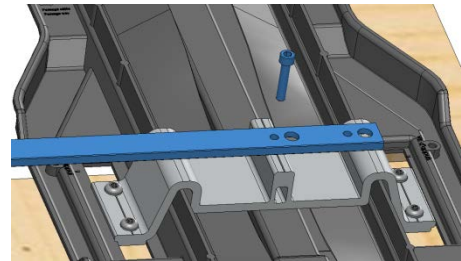
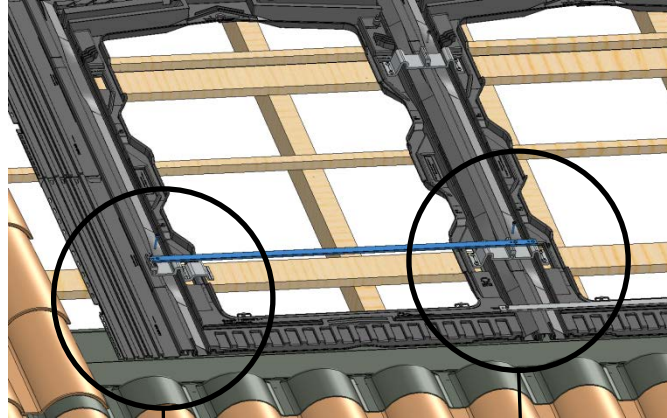

9.5)

Installation of the EASY-ROOF system

1°) Position the photovoltaic modules. For grounding, see page 48.

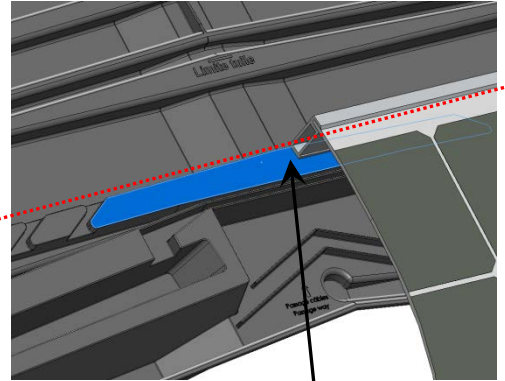
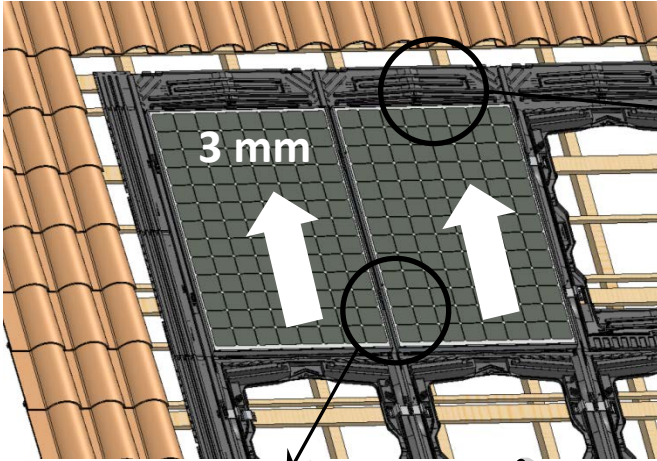

(Local Cut on PV module)



For PV modules with a short back frame, align the higher edge of the module with the top point of the « leaning area » as shown on the drawing.

2°) Position the middle clamp (5 or 6) with the module wedge above the middle bracket between two module, the clamp leaning against the PV modules.

3°) Slide the clamp downwards to interlock it on the middle bracket.

4°) Push the modules against the module wedge.

5°) Before tightening, raise approximately 3 MINI mm the PV so that it is not any more leaning on its own weight. **VERY IMPORTANT**, this play is necessary for dilation.

6°) Screw with a screw CHc M6 X 30 (12) or CHc M6 X 40 (11) according to the thickness of PV module.

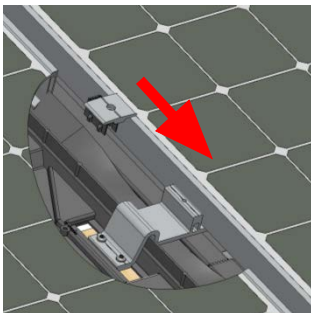
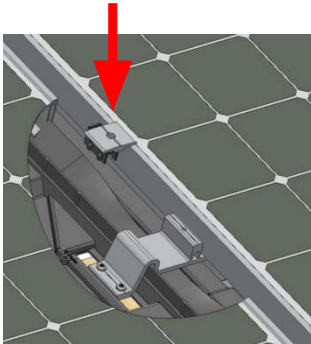

(Local Cut on PV module)

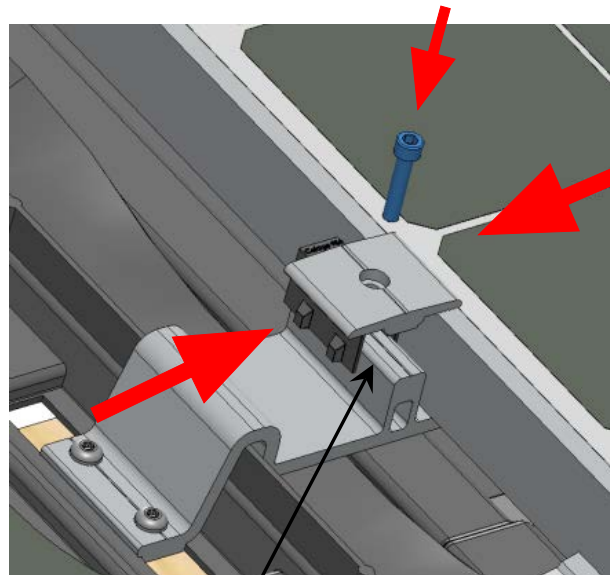

Tightening torque 8.8 Nm

7°) Place all the middle bracket on the PV field

9.5)

Installation of the EASY-ROOF system

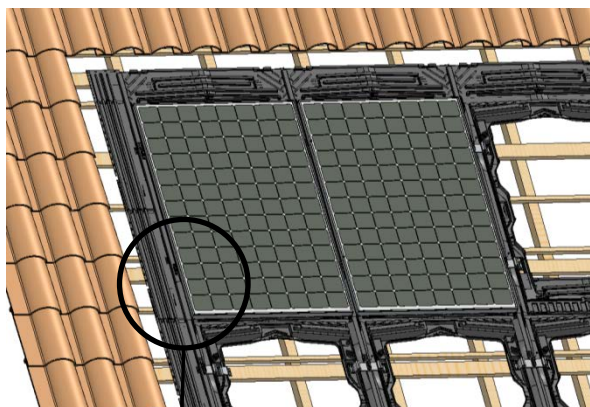

(End bracket)

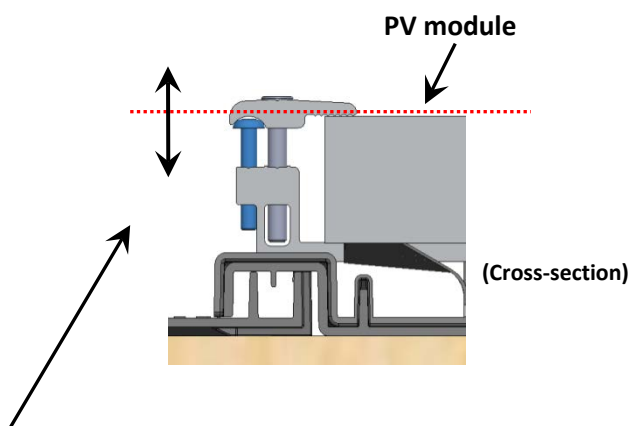
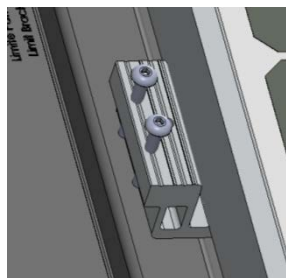

1°) Adjust the height of the screws on the end bracket so that they are flush with the top of the PV module.

2°) Fix the PV modules with the end clamps (4) using screws CHc M6 X 30 (12) or CHc M6 X 40 (11) according to the thickness of the PV module.

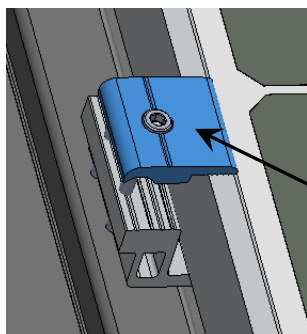

Tightening torque 8.8 Nm

(End clamp)

9.5.1)

Grounding

If grounding is not done by connecting the ground wire directly to PV module, carry out the following operations.

1 °) Locate the middle bracket connected to the ground during the assembly.(see p. 36)

Option 1°)

Scratch the top of the PV module frame above the brackets connected to the ground. This ensure connection to the ground via the screws located on clamp.

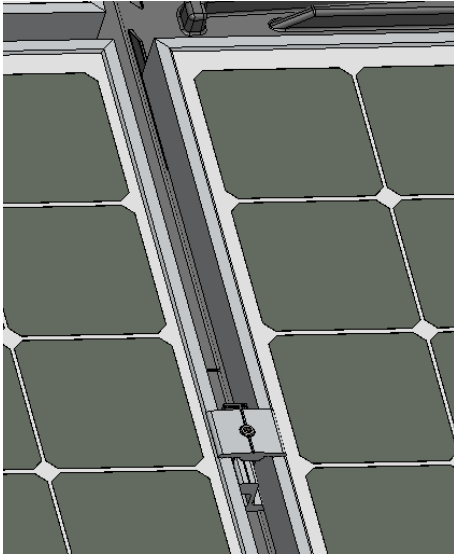

Make scratches here on the PV module

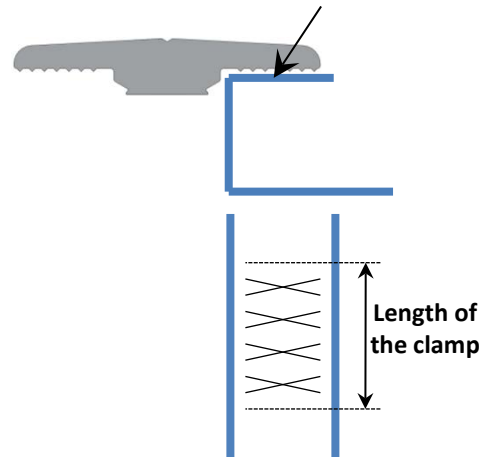

Option 2°)

Place the claw on the back side of the PV module where it will lean so that it is resting against the mounting bracket connected to the ground.

Scratch on PV module

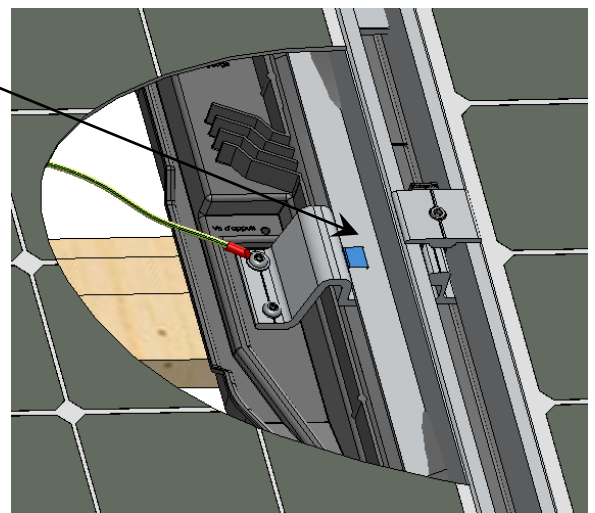
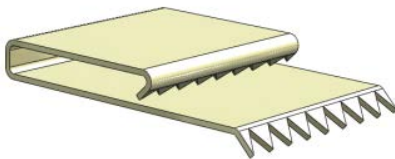

(view with local cut)

2°) Make sure then that connection between the PV module and the bracket(5) is less than 2 Ohms.

9.6) Put back the tiles

Put back the tiles, covering the top flashing up to the marking indicating "Limit tile".

IMPORTANT: For the tiles with high profile, it is imperative to set up a self-adhesive foam band on the top flashing before replacing the tiles.

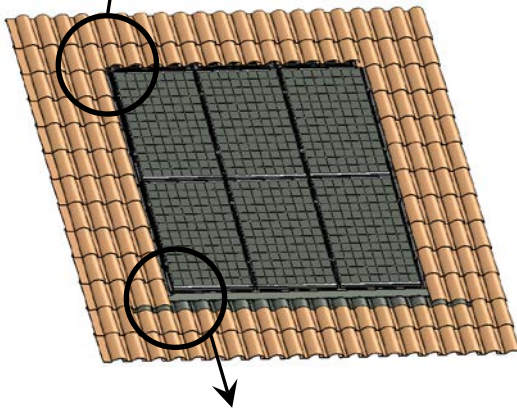
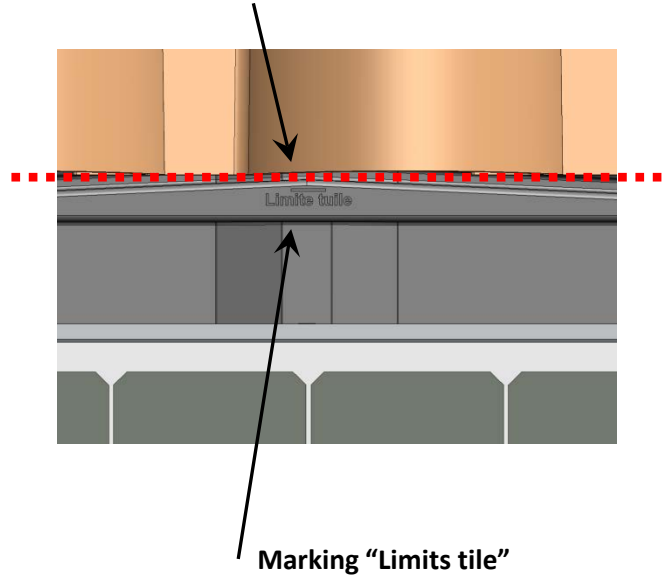
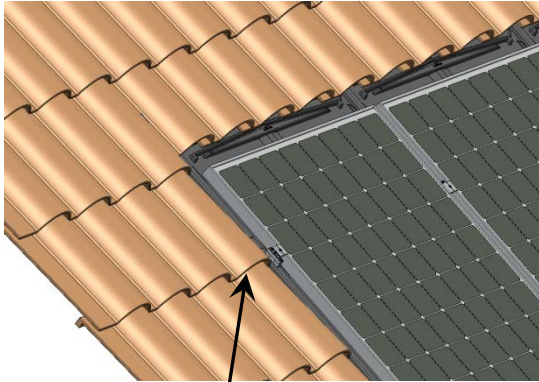

For the covering of the side flashings (2) and (3), the edge of the tiles have to be as close as possible to the marking indicating "Limit tile".

It is imperative that the dimension D does not exceed 40 mm MAXIMUM

Dimension D

